

EMUGE
FRANKEN

■ Made
■ in
■ Germany

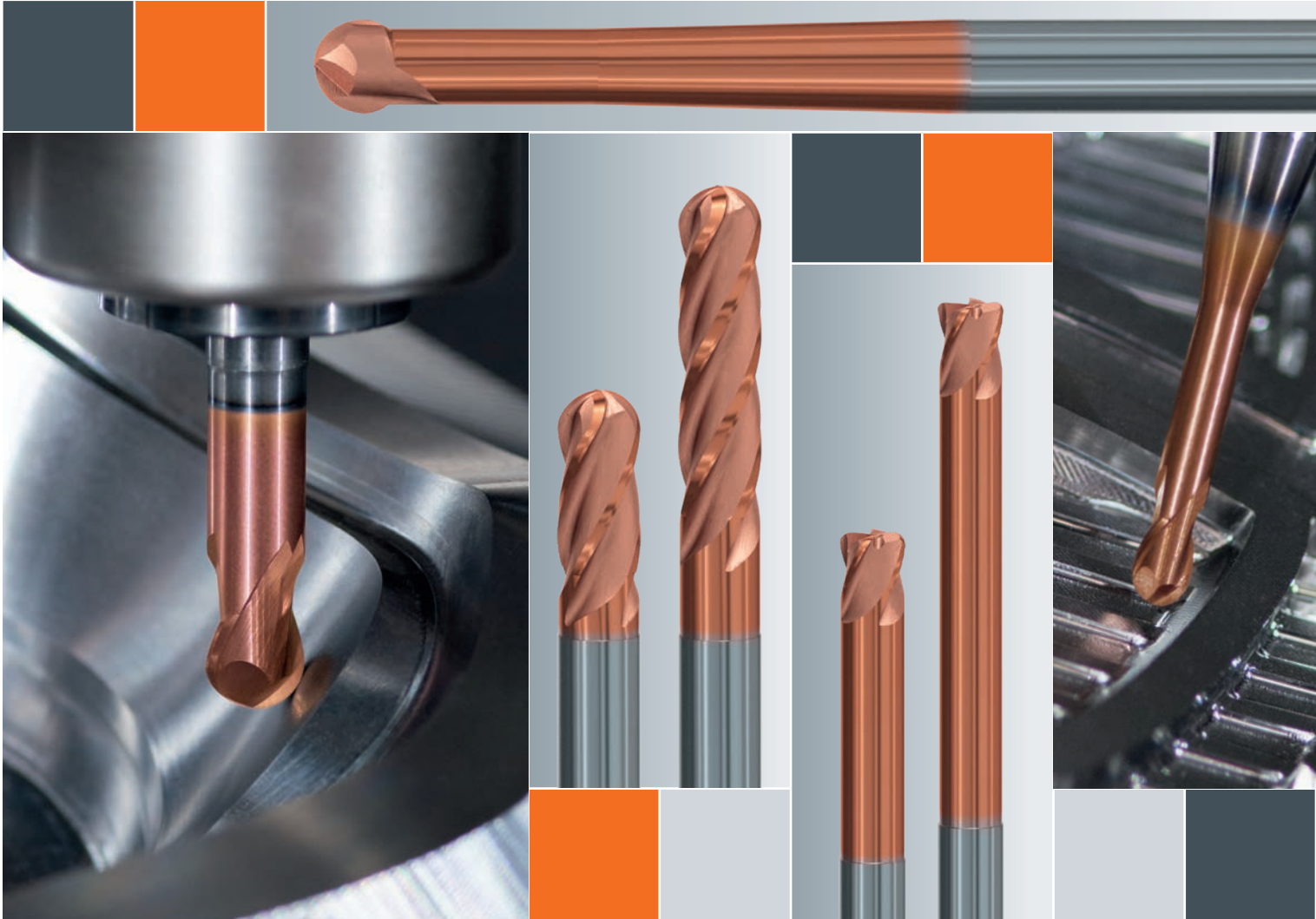

FRANKEN
TOP-Cut

Universalfräser für den Werkzeug- und Formenbau
Universal End Mills for the Die and Mould Industry



Mehr als 100 Jahre Präzision und Innovation. More than 100 years of precision and innovation.

FRANKEN als Teil der EMUGE-FRANKEN Unternehmensgruppe beschäftigt sich seit seiner Gründung mit der Entwicklung und Produktion von Fräswerkzeugen. Präzision und Innovation prägen das breite Angebot von Fräsern aus Hartmetall und HSS sowie PKD-, CBN- oder wendepplattenbestückten Fräskörpern.

Die Fertigung am deutschen Produktionsstandort in Rückersdorf reicht von Standard-Schaft- und Bohrungsfräsern bis hin zu hochgenauen Form- und Profil-Sonderfräsern. Mit seiner Typen- und Schneidstoffvielfalt, dem hohen Standard und der kompromisslosen Präzision entspricht das Fräserprogramm den höchsten Qualitätsanforderungen.

Als Ergänzung zu den Fräswerkzeugen führt FRANKEN ein durchgängiges Programm an Fräterspannmitteln und Zubehör für die verschiedensten Adaptierungsmöglichkeiten.

Ever since its foundation FRANKEN as part of the EMUGE-FRANKEN company association has been developing and manufacturing milling tools. The wide range of end mills of solid carbide and HSS as well as PCD and CBN inserts or milling cutters with indexable inserts is characterised by precision and innovation.

The production in our German manufacturing plant in Rückersdorf includes standard end mills and bore cutters as well as highly precise special form and profile milling tools. With its large variety of tool types and cutting materials, the consistently high standards and uncompromising precision, our product range of milling cutters meets even the highest quality requirements.

In addition to our selection of milling tools, we also offer a comprehensive range of clamping systems, tool holders and accessories.



Produktionsstandort in Deutschland
Production location in Germany





In dieser Broschüre wird eine Auswahl der wichtigsten FRANKEN TOP-Cut Hartmetall-Kugel- und -Torusfräser dargestellt. Diese sind speziell auf den Werkzeug- und Formenbau abgestimmt. Dank einer universellen Werkzeuggeometrie können verschiedenste Materialien im Bereich der Schrupp- und Schlichtbearbeitung zerspannt werden. Der Einsatz auf modernen Zerspanungszentren mit 5-Achs-Technologie ist ebenfalls möglich.

Zu jedem Werkzeug werden – in Abhängigkeit zur jeweiligen Werkstoffgruppe – sichere Startbedingungen für die Schnittgeschwindigkeit v_c und den Vorschub pro Zahn f_z , sowie Hinweise zu empfohlenen Kühlschmierstoffen angegeben.

Besonderheiten:

- Universelle Schneidengeometrie
- Verschiedene Baulängen
- Unterschiedliche, hochgenaue Eckenradien
- Moderner Schneidstoff
- Hochleistungs-Beschichtung

Hauptmerkmal:

- In fast allen Werkstoffen einsetzbar
- Zum Schruppen, Schlichten sowie zum HSC-Schlichten geeignet

Im FRANKEN Katalog 250 finden Sie weitere Werkzeuge für den Einsatz im Werkzeug- und Formenbau.

This brochure presents a selection of the most important FRANKEN TOP-Cut carbide ball nose and torus end mills. These are specially designed for the die and mould industry. Thanks to a universal tool geometry different materials can be machined in roughing and finishing operations. The use of these tools on modern machining centres with 5-axis technology is also possible.

Machining recommendations are provided for each tool taking the respective material group into account, including safe starting conditions for the cutting speed v_c and feed per tooth f_z as well as advice on recommended coolant-lubricants.

Characteristics:

- Universal flute geometry
- Different lengths
- Different, highly accurate corner radii
- Modern cutting material
- High performance coating

Main feature:

- For almost all materials
- Suitable for roughing, finishing and HSC finishing

Additional tools for the application in die and mould making can be found in the FRANKEN catalogue 250.

Inhalt

	Seite
Wegweiser	4 - 6
Hartmetall-Kugelfräser	8 - 27
Hartmetall-Torusfräser	28 - 37
Werkzeugprogramm und Druckerzeugnisse.....	38
Die Weiterentwicklung der Schlichtbearbeitung	39
Kaltluftdüse mit Zubehör	40 - 42
Anwendungstechnik	43

Content

	Page
Product finder	4 - 6
Solid carbide ball nose end mills	8 - 27
Solid carbide torus end mills	38 - 37
Tool programme and sales literature	38
The advanced development of finish machining	39
Cold-air nozzle and accessories	40 - 42
Technical Service	43

Wegweiser

Bitte beachten:

Die Eignung der Hartmetall-Kugel- und Torusfräser ist folgendermaßen gekennzeichnet:

- = sehr gut geeignet
- = gut geeignet

Product finder

Please note:

The suitability of the solid carbide ball nose and torus end mills is indicated as follows:

- = very suitable
- = suitable

Einsatzgebiete – Material Applications – material			Material-Beispiele Material examples	Material-Nummern Material numbers
P	Stahlwerkstoffe Steel materials			
	1.1 Kaltfließpressstähle, Baustähle, Automatenstähle, u.a.	Cold-extrusion steels, Construction steels, Free-cutting steels, etc.	≤ 600 N/mm ²	Cq15 1.1132 S235JR (St37-2) 1.0037 10SPb20 1.0722
	2.1 Baustähle, Einsatzstähle, Stahlguss, u.a.	Construction steels, Case-hardened steels, Steel castings, etc.	≤ 800 N/mm ²	E360 (St70-2) 1.0070 16MnCr5 1.7131 GS-25CrMo4 1.7218
	3.1 Einsatzstähle, Vergütungsstähle, Kaltarbeitsstähle, u.a.	Case-hardened steels, Heat-treatable steels, Cold work steels, etc.	≤ 1000 N/mm ²	20MoCr3 1.7320 42CrMo4 1.7225 102Cr6 1.2067 50CrMo4 1.7228
	4.1 Vergütungsstähle, Kaltarbeitsstähle, Nitrierstähle, u.a.	Heat-treatable steels, Cold work steels, Nitriding steels, etc.	≤ 1200 N/mm ²	X45NiCrMo4 1.2767 31CrMo12 1.8515
5.1 Hochlegierte Stähle, Kaltarbeitsstähle, Warmarbeitsstähle, u.a.	High-alloyed steels, Cold work steels, Hot work steels, etc.	≤ 1400 N/mm ²	X38CrMoV5-3 1.2367 X100CrMoV8-1-1 1.2990 X40CrMoV5-1 1.2344	
M	Nichtrostende Stahlwerkstoffe Stainless steel materials			
	1.1 Ferritisch, martensitisch	Ferritic, martensitic	≤ 950 N/mm ²	X2CrTi12 1.4512
	2.1 Austenitisch	Austenitic	≤ 950 N/mm ²	X6CrNiMoTi17-12-2 1.4571
	3.1 Austenitisch-ferritisch (Duplex)	Austenitic-ferritic (Duplex)	≤ 1100 N/mm ²	X2CrNiMoN22-5-3 1.4462
4.1 Austenitisch-ferritisch hitzebeständig (Super Duplex)	Austenitic-ferritic heat-resistant (Super Duplex)	≤ 1250 N/mm ²	X2CrNiMoN25-7-4 1.4410	
K	Gusswerkstoffe Cast materials			
	1.1 Gusseisen mit Lamellengrafit (GJL)	Cast iron with lamellar graphite (GJL)	100-250 N/mm ²	EN-GJL-200 (GG20) EN-JL-1030
	1.2 Gusseisen mit Kugelgrafit (GJS)	Cast iron with nodular graphite (GJS)	250-450 N/mm ²	EN-GJL-300 (GG30) EN-JL-1050
	2.1 Gusseisen mit Kugelgrafit (GJS)	Cast iron with nodular graphite (GJS)	350-500 N/mm ²	EN-GJS-400-15 (GGG40) EN-JS-1030
	2.2 Gusseisen mit Kugelgrafit (GJS)	Cast iron with nodular graphite (GJS)	500-900 N/mm ²	EN-GJS-700-2 (GGG70) EN-JS-1070
	3.1 Gusseisen mit Vermiculargrafit (GJV)	Cast iron with vermicular graphite (GJV)	300-400 N/mm ²	GJV 300
	3.2 Gusseisen mit Vermiculargrafit (GJV)	Cast iron with vermicular graphite (GJV)	400-500 N/mm ²	GJV 450
4.1 Temperguss (GTMW, GTMB)	Malleable cast iron (GTMW, GTMB)	250-500 N/mm ²	EN-GJMW-350-4 (GTW-35) EN-JM-1010	
4.2 Temperguss (GTMW, GTMB)	Malleable cast iron (GTMW, GTMB)	500-800 N/mm ²	EN-GJMB-450-6 (GTS-45) EN-JM-1140	
N	Nichteisenwerkstoffe Non-ferrous materials			
	1.1 Aluminium-Legierungen	Aluminium alloys		
	1.2 Aluminium-Knetlegierungen	Wrought aluminium alloys	≤ 200 N/mm ²	EN AW-AlMn1 EN AW-3103
	1.3 Aluminium-Knetlegierungen	Wrought aluminium alloys	≤ 350 N/mm ²	EN AW-AlMgSi EN AW-6060
	1.4 Aluminium-Knetlegierungen	Wrought aluminium alloys	≤ 550 N/mm ²	EN AW-AlZn5Mg3Cu EN AW-7022
	1.5 Aluminium-Gusslegierungen	Aluminium cast alloys	Si ≤ 7%	EN AC-AlMg5 EN AC-51300
	1.6 Aluminium-Gusslegierungen	Aluminium cast alloys	7% < Si ≤ 12%	EN AC-AISi9Cu3 EN AC-46500
	1.6 Aluminium-Gusslegierungen	Aluminium cast alloys	12% < Si ≤ 17%	GD-AISi17Cu4FeMg
	2.1 Reinkupfer, niedriglegiertes Kupfer	Pure copper, low-alloyed copper	≤ 400 N/mm ²	E-Cu 57
	2.2 Kupfer-Zink-Legierungen (Messing, langspanend)	Copper-zinc alloys (brass, long-chipping)	≤ 550 N/mm ²	CuZn37 (Ms63) EN CW 508 L
	2.3 Kupfer-Zink-Legierungen (Messing, kurzspanend)	Copper-zinc alloys (brass, short-chipping)	≤ 550 N/mm ²	CuZn36Pb3 (Ms58) EN CW 603 N
	2.4 Kupfer-Aluminium-Legierungen (Alubronze, langspanend)	Copper-aluminium alloys (alu bronze, long-chipping)	≤ 800 N/mm ²	CuAl10Ni5Fe4 EN CW 307 G
	2.5 Kupfer-Zinn-Legierungen (Zinnbronze, langspanend)	Copper-tin alloys (tin bronze, long-chipping)	≤ 700 N/mm ²	CuSn8P EN CW 459 K
	2.6 Kupfer-Zinn-Legierungen (Zinnbronze, kurzspanend)	Copper-tin alloys (tin bronze, short-chipping)	≤ 400 N/mm ²	CuSn7 ZnPb (Rg7) 2.1090
	2.7 Kupfer-Sonderlegierungen	Special copper alloys	≤ 600 N/mm ²	(AMPCO® 8)
	2.8 Kupfer-Sonderlegierungen	Special copper alloys	≤ 1400 N/mm ²	(AMPCO® 45)
3.1 Magnesium-Knetlegierungen	Magnesium wrought alloys	≤ 500 N/mm ²	MgAl6Zn 3.5612	
3.2 Magnesium-Gusslegierungen	Magnesium cast alloys	≤ 500 N/mm ²	EN-MCMgAl9Zn1 EN-MC21120	
4.1 Duroplaste (kurzspanend)	Duroplastics (short-chipping)		Bakelit, Pertinax	
4.2 Thermoplaste (langspanend)	Thermoplastics (long-chipping)		PMMA, POM, PVC	
4.3 Faserverstärkte Kunststoffe (Faseranteil ≤ 30%)	Fibre-reinforced synthetics (fibre content ≤ 30%)		GFK, CFK, AFK	
4.4 Faserverstärkte Kunststoffe (Faseranteil > 30%)	Fibre-reinforced synthetics (fibre content > 30%)		GFK, CFK, AFK	
5.1 Grafit	Graphite		C 8000	
5.2 Wolfram-Kupfer-Legierungen	Tungsten-copper alloys		W-Cu 80/20	
5.3 Verbundwerkstoffe	Composite materials		Hyllite, Alucobond	
S	Spezialwerkstoffe Special materials			
	1.1 Titan-Legierungen	Titanium alloys		
	1.2 Reintitan	Pure titanium	≤ 450 N/mm ²	Ti1 3.7025
	1.3 Titan-Legierungen	Titanium alloys	≤ 900 N/mm ²	TiAl6V4 3.7165
	1.3 Titan-Legierungen	Titanium alloys	≤ 1250 N/mm ²	TiAl4Mo4Sn2 3.7185
	2.1 Nickel-, Kobalt- und Eisen-Legierungen	Nickel alloys, cobalt alloys and iron alloys		
	2.2 Reinnickel	Pure nickel	≤ 600 N/mm ²	Ni 99.6 2.4060
	2.3 Nickel-Basis-Legierungen	Nickel-base alloys	≤ 1000 N/mm ²	Monel 400 2.4360
	2.3 Nickel-Basis-Legierungen	Nickel-base alloys	≤ 1600 N/mm ²	Inconel 718 2.4668
	2.4 Kobalt-Basis-Legierungen	Cobalt-base alloys	≤ 1000 N/mm ²	Udimet 605
2.5 Eisen-Basis-Legierungen	Iron-base alloys	≤ 1600 N/mm ²	Haynes 25 2.4964	
2.6 Eisen-Basis-Legierungen	Iron-base alloys	≤ 1500 N/mm ²	Incoloy 800 1.4958	
H	Harte Werkstoffe Hard materials			
	1.1 Hochfeste Stähle, gehärtete Stähle, Hartguss	High strength steels, hardened steels, hard castings	44 - 50 HRC	Weldox 1100
	1.2 Hochfeste Stähle, gehärtete Stähle, Hartguss	High strength steels, hardened steels, hard castings	50 - 55 HRC	Hardox 550
	1.3 Hochfeste Stähle, gehärtete Stähle, Hartguss	High strength steels, hardened steels, hard castings	55 - 60 HRC	Armox 600T
	1.4 Hochfeste Stähle, gehärtete Stähle, Hartguss	High strength steels, hardened steels, hard castings	60 - 63 HRC	Ferro-Titanit
	1.5 Hochfeste Stähle, gehärtete Stähle, Hartguss	High strength steels, hardened steels, hard castings	63 - 66 HRC	HSSE

Hartmetall-Kugelfräser
Solid carbide ball nose end mills

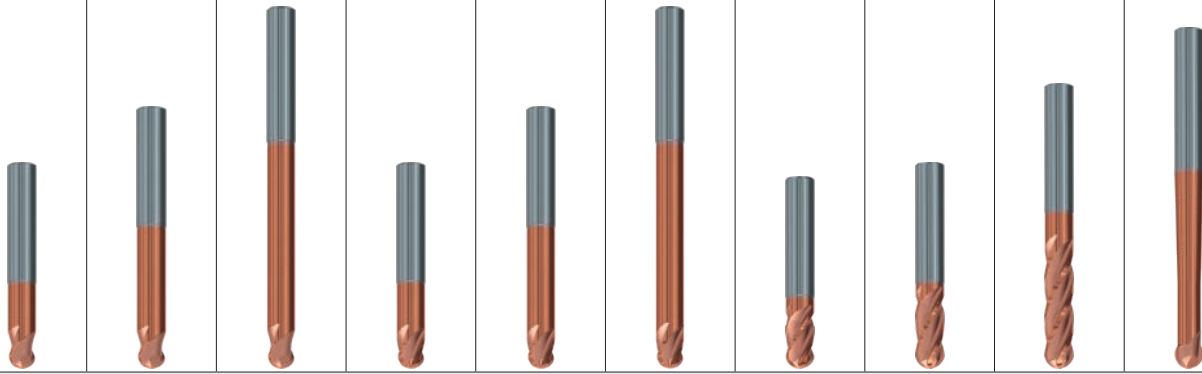

Allround

N

ø0,5-12mm	ø0,5-12mm	ø0,5-8 mm	ø2-12mm	ø2-12mm	ø2-8mm	ø3-16mm	ø2-16mm	ø6-16mm	ø2-12mm	Z (Flutes)
2	2	2	4	4	4	3 - 4	3 - 4	4	2	Z (Flutes)
3820A	3821A	3822A	3823A	3824A	3825A	3840A	2502A	2504A	1935A	
8	10	12	14	16	18	20	22	24	26	Seite · Page
9	11	13	15	17	19	21	23	25	27	

■	■	■	■	■	■	■	■	■	■	1.1	P
■	■	■	■	■	■	■	■	■	■	2.1	
■	■	■	■	■	■	■	■	■	■	3.1	
■	■	■	■	■	■	■	■	■	■	4.1	
■	■	■	■	■	■	■	■	■	■	5.1	
■	■	■	■	■	■	■	■	■	■	1.1	M
■	■	■	■	■	■	□	□	□	■	2.1	
■	■	■	■	■	■	□	□	□	■	3.1	
■	■	■	■	■	■	□	□	□	■	4.1	
■	■	■	■	■	■	■	■	■	■	1.1	K
■	■	■	■	■	■	■	■	■	■	1.2	
■	■	■	■	■	■	■	■	■	■	2.1	
■	■	■	■	■	■	■	■	■	■	2.2	
■	■	■	■	■	■	□	□	□	■	3.1	
■	■	■	■	■	■	□	□	□	■	3.2	
■	■	■	■	■	■	□	□	□	■	4.1	
■	■	■	■	■	■	□	□	□	■	4.2	
□	□	□	□	□	□				□	1.1	N
□	□	□	□	□	□				□	1.2	
□	□	□	□	□	□				□	1.3	
□	□	□	□	□	□				□	1.4	
□	□	□	□	□	□				□	1.5	
□	□	□	□	□	□				□	1.6	
■	■	■	■	■	■	■	■	■	■	2.1	
■	■	■	■	■	■	■	■	■	■	2.2	
■	■	■	■	■	■	■	■	■	■	2.3	
■	■	■	■	■	■	■	■	■	■	2.4	
■	■	■	■	■	■	■	■	■	■	2.5	
■	■	■	■	■	■	■	■	■	■	2.6	
■	■	■	■	■	■	■	■	■	■	2.7	
■	■	■	■	■	■	■	■	■	■	2.8	
										3.1	
										3.2	
							■	■	■	4.1	
							■	■	■	4.2	
										4.3	
										4.4	
■	■	■	■	■	■	■	■	■	□	5.1	
							■	■	■	5.2	
										5.3	
■	■	■	■	■	■	■	■	■	■	1.1	S
■	■	■	■	■	■	■	■	■	■	1.2	
■	■	■	■	■	■	■	■	■	■	1.3	
□	□	□	■	■	■	■	■	■	■	2.1	
□	□	□	■	■	■	■	■	■	■	2.2	
□	□	□	■	■	■	■	■	■	■	2.3	
□	□	□	■	■	■	■	■	■	■	2.4	
□	□	□	■	■	■	■	■	■	■	2.5	
□	□	□	■	■	■	■	■	■	■	2.6	
■	■	■	■	■	■	■	■	■	■	1.1	H
■	■	■	■	■	■	■	■	■	■	1.2	
										1.3	
										1.4	
										1.5	

Hartmetall-Torusfräser
Solid carbide torus end mills

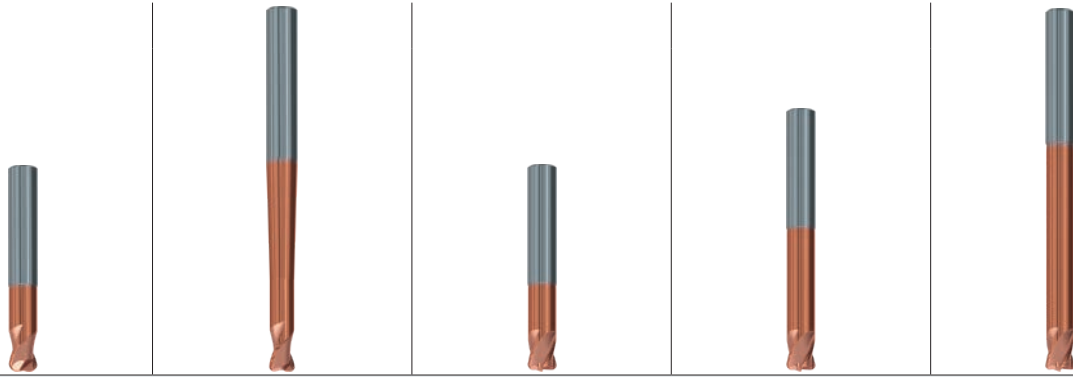

Allround

N

	ø0,5-12mm	ø1-12mm	ø2-12mm	ø2-12mm	ø2-8mm
Z (Flutes)	2	2	4	4	4
	2552A	2553A	3835A	3836A	3837A
Seite · Page	28	30	32	34	36
v_c / f_z	29	31	33	35	37
P	1.1	■	■	■	■
	2.1	■	■	■	■
	3.1	■	■	■	■
	4.1	■	■	■	■
	5.1	■	■	■	■
M	1.1	■	■	■	■
	2.1	■	■	■	■
	3.1	■	■	■	■
	4.1	■	■	■	■
K	1.1	■	■	■	■
	1.2	■	■	■	■
	2.1	■	■	■	■
	2.2	■	■	■	■
	3.1	■	■	■	■
	3.2	■	■	■	■
	4.1	■	■	■	■
	4.2	■	■	■	■
N	1.1				
	1.2	□	□		
	1.3	□	□		
	1.4	□	□		
	1.5				
	1.6				
	2.1	■	■	□	□
	2.2	■	■	■	■
	2.3	■	■	■	■
	2.4	■	■	■	■
	2.5	■	■	■	■
	2.6	■	■	■	■
	2.7	■	■	■	■
	2.8	■	■	■	■
	3.1				
	3.2				
4.1					
4.2					
4.3					
4.4					
5.1					
5.2	■	■	■	■	
5.3					
S	1.1		■	■	■
	1.2		■	■	■
	1.3		■	■	■
	2.1	■	■	■	■
	2.2	■	■	■	■
	2.3	■	■	■	■
	2.4	□	□	■	■
2.5	□	□	■	■	
2.6	□	□	■	■	
H	1.1	■	■	■	■
	1.2	■	■	■	■
	1.3				
	1.4				
	1.5				



24/7

Unsere Vielfalt auf · Precision Tools on
www.emuge-franken.com

Anmelden  Waren
annehmen  Kont



Mit dem bei den Werkzeugen abgebildeten QR-Code gelangen Sie direkt zu den jeweiligen Artikeln in unserem Webshop. Dort finden Sie umfassende Werkzeuginformationen und Schnittdaten.

Bei Registrierung stehen Ihnen noch weitere Produktdaten und Funktionen zur Verfügung. Dazu zählen neben standardisierten Werkzeugdaten (2D / 3D / Sachmerkmale) auch eine Bestell- oder Angebotshistorie, individuelle Merklisten sowie weitere nützliche Funktionen.

The QR code shown with the tools will take you directly to the respective articles in our web store where you can find comprehensive tool information and cutting data.

Registration provides you with additional product data and functions. These include standardised tool data (2D / 3D / characteristics), an order or quotation history and individual watch lists as well as other useful functions.

- Multifunktionales Hochleistungswerkzeug
- Optimierte Querschnitte
- 3 Baulängen verfügbar

- Multi-functional, high performance tool
- Optimised chisel edge
- 3 lengths available

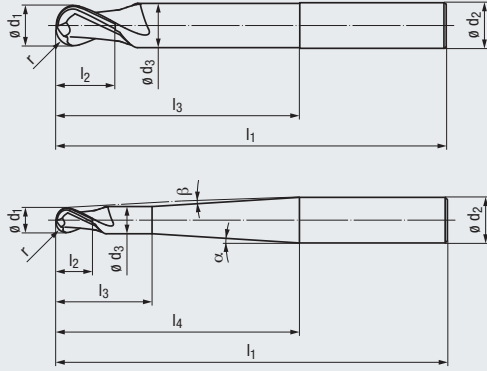

N

HM

DIN 6535
HA
HB

30° **Kugel**

MMS
MQL

≤ 55 HRC

V_c/f_z
9



NEW



Allround

Beschichtung · Coating

TIALN

Einsatzgebiete – Material (siehe Seite 4)

Applications – material (see page 4)

- In fast allen Werkstoffen einsetzbar
- Zum Schrappen, Schlichten sowie zum HSC-Schlichten geeignet

- For almost all materials
- Suitable for roughing, finishing and HSC finishing

P 1.1-5.1

M 1.1-4.1

K 1.1-4.2

N 2.1-2.8, 5.2 | 1.2-1.4

S 1.1-1.3 | 2.1-2.6

H 1.1-1.2

l₃ = 3 x d₁ – Kurze Ausführung · Short design

Bestell-Code · Order code

3820A

∅ d ₁	r	l ₂	l ₃	l ₁	∅ d ₃	l ₄	∅ d ₂ h5	α	β	Z (Flutes)	Dimens.- Code	
-0,02	-0,01											
0,5	0,25	1	2	54	0,45	17,7	6	10°	9°	2	.0005	●
1	0,5	2	4	57	0,95	18,3	6	10°	8,5°	2	.001	●
1,5	0,75	2,5	4,5	57	1,4	17,5	6	10°	8,5°	2	.0015	●
2	1	3	8	57	1,8	19,9	6	10°	6,5°	2	.002	●
3	1,5	3,5	10	57	2,8	19	6	10°	5,5°	2	.003	●
4	2	4	12	57	3,8	18,2	6	10°	3,5°	2	.004	●
5	2,5	5	15	57	4,7	18,6	6	10°	2°	2	.005	●
6	3	6	20	57	5,6	–	6	–	–	2	.006	●
8	4	7	25	63	7,6	–	8	–	–	2	.008	●
10	5	8	30	72	9,6	–	10	–	–	2	.010	●
12	6	10	36	83	11,5	–	12	–	–	2	.012	●



Hartmetall-Kugelfräser – kurze Ausführung (2 Schneiden)
Solid carbide ball nose end mills – short design (2 flutes)

N

$l_3 = 3 \times d_1$

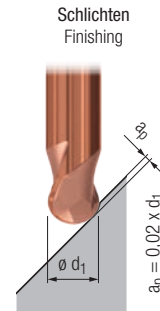
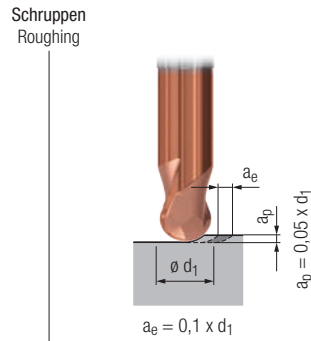
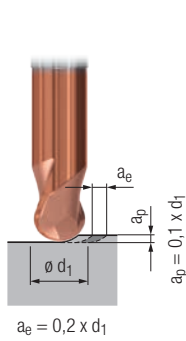

Gültig für · Valid for
3820A

	V_c [m/min]	f_z [mm]	V_c [m/min]	f_z [mm]	V_c [m/min]	f_z [mm]			MMS MQL		
P	1.1	260	$0,013 \times d_1$	280	$0,015 \times d_1$	300	$0,013 \times d_1$	<input type="checkbox"/>	<input checked="" type="checkbox"/>	<input type="checkbox"/>	<input checked="" type="checkbox"/>
	2.1	240	$0,012 \times d_1$	260	$0,014 \times d_1$	280	$0,012 \times d_1$	<input type="checkbox"/>	<input checked="" type="checkbox"/>	<input type="checkbox"/>	<input checked="" type="checkbox"/>
	3.1	220	$0,011 \times d_1$	240	$0,013 \times d_1$	260	$0,011 \times d_1$	<input type="checkbox"/>	<input checked="" type="checkbox"/>	<input type="checkbox"/>	<input type="checkbox"/>
	4.1	200	$0,010 \times d_1$	220	$0,012 \times d_1$	240	$0,010 \times d_1$	<input type="checkbox"/>	<input checked="" type="checkbox"/>	<input type="checkbox"/>	<input type="checkbox"/>
	5.1	180	$0,009 \times d_1$	200	$0,010 \times d_1$	220	$0,009 \times d_1$	<input type="checkbox"/>	<input checked="" type="checkbox"/>	<input type="checkbox"/>	<input type="checkbox"/>
M	1.1	140	$0,008 \times d_1$	160	$0,009 \times d_1$	180	$0,010 \times d_1$	<input type="checkbox"/>	<input type="checkbox"/>	<input type="checkbox"/>	<input checked="" type="checkbox"/>
	2.1	120	$0,008 \times d_1$	140	$0,009 \times d_1$	160	$0,010 \times d_1$	<input type="checkbox"/>	<input type="checkbox"/>	<input type="checkbox"/>	<input checked="" type="checkbox"/>
	3.1	100	$0,006 \times d_1$	110	$0,007 \times d_1$	120	$0,008 \times d_1$	<input type="checkbox"/>	<input type="checkbox"/>	<input type="checkbox"/>	<input checked="" type="checkbox"/>
	4.1	80	$0,006 \times d_1$	90	$0,007 \times d_1$	100	$0,008 \times d_1$	<input type="checkbox"/>	<input type="checkbox"/>	<input type="checkbox"/>	<input checked="" type="checkbox"/>
K	1.1	260	$0,011 \times d_1$	280	$0,013 \times d_1$	300	$0,010 \times d_1$	<input type="checkbox"/>	<input checked="" type="checkbox"/>	<input type="checkbox"/>	<input type="checkbox"/>
	1.2	260	$0,011 \times d_1$	280	$0,013 \times d_1$	300	$0,010 \times d_1$	<input type="checkbox"/>	<input checked="" type="checkbox"/>	<input type="checkbox"/>	<input type="checkbox"/>
	2.1	220	$0,011 \times d_1$	240	$0,013 \times d_1$	260	$0,010 \times d_1$	<input type="checkbox"/>	<input checked="" type="checkbox"/>	<input type="checkbox"/>	<input type="checkbox"/>
	2.2	220	$0,011 \times d_1$	240	$0,013 \times d_1$	260	$0,010 \times d_1$	<input type="checkbox"/>	<input checked="" type="checkbox"/>	<input type="checkbox"/>	<input type="checkbox"/>
	3.1	180	$0,010 \times d_1$	200	$0,011 \times d_1$	220	$0,008 \times d_1$	<input type="checkbox"/>	<input checked="" type="checkbox"/>	<input type="checkbox"/>	<input type="checkbox"/>
	3.2	180	$0,010 \times d_1$	200	$0,011 \times d_1$	220	$0,008 \times d_1$	<input type="checkbox"/>	<input checked="" type="checkbox"/>	<input type="checkbox"/>	<input type="checkbox"/>
	4.1	140	$0,008 \times d_1$	160	$0,009 \times d_1$	180	$0,007 \times d_1$	<input type="checkbox"/>	<input checked="" type="checkbox"/>	<input type="checkbox"/>	<input type="checkbox"/>
	4.2	130	$0,008 \times d_1$	140	$0,009 \times d_1$	150	$0,007 \times d_1$	<input type="checkbox"/>	<input checked="" type="checkbox"/>	<input type="checkbox"/>	<input type="checkbox"/>
N	1.1										
	1.2	400	$0,015 \times d_1$	420	$0,017 \times d_1$	450	$0,014 \times d_1$	<input type="checkbox"/>	<input type="checkbox"/>	<input type="checkbox"/>	<input checked="" type="checkbox"/>
	1.3	350	$0,014 \times d_1$	370	$0,016 \times d_1$	400	$0,013 \times d_1$	<input type="checkbox"/>	<input type="checkbox"/>	<input type="checkbox"/>	<input checked="" type="checkbox"/>
	1.4	280	$0,013 \times d_1$	300	$0,015 \times d_1$	350	$0,012 \times d_1$	<input type="checkbox"/>	<input type="checkbox"/>	<input type="checkbox"/>	<input checked="" type="checkbox"/>
	1.5										
	1.6										
	2.1	200	$0,012 \times d_1$	260	$0,012 \times d_1$	280	$0,010 \times d_1$	<input type="checkbox"/>	<input type="checkbox"/>	<input type="checkbox"/>	<input checked="" type="checkbox"/>
	2.2	200	$0,012 \times d_1$	260	$0,012 \times d_1$	280	$0,010 \times d_1$	<input type="checkbox"/>	<input type="checkbox"/>	<input type="checkbox"/>	<input checked="" type="checkbox"/>
	2.3	200	$0,012 \times d_1$	260	$0,012 \times d_1$	280	$0,010 \times d_1$	<input type="checkbox"/>	<input type="checkbox"/>	<input type="checkbox"/>	<input checked="" type="checkbox"/>
	2.4	160	$0,010 \times d_1$	220	$0,010 \times d_1$	250	$0,008 \times d_1$	<input type="checkbox"/>	<input type="checkbox"/>	<input type="checkbox"/>	<input checked="" type="checkbox"/>
	2.5	160	$0,010 \times d_1$	220	$0,010 \times d_1$	250	$0,008 \times d_1$	<input type="checkbox"/>	<input type="checkbox"/>	<input type="checkbox"/>	<input checked="" type="checkbox"/>
	2.6	160	$0,010 \times d_1$	220	$0,010 \times d_1$	250	$0,008 \times d_1$	<input type="checkbox"/>	<input type="checkbox"/>	<input type="checkbox"/>	<input checked="" type="checkbox"/>
	2.7	150	$0,008 \times d_1$	180	$0,008 \times d_1$	200	$0,006 \times d_1$	<input type="checkbox"/>	<input type="checkbox"/>	<input type="checkbox"/>	<input checked="" type="checkbox"/>
	2.8	120	$0,008 \times d_1$	140	$0,008 \times d_1$	160	$0,006 \times d_1$	<input type="checkbox"/>	<input type="checkbox"/>	<input type="checkbox"/>	<input checked="" type="checkbox"/>
	3.1										
	3.2										
4.1											
4.2											
4.3											
4.4											
5.1											
5.2	130	$0,008 \times d_1$	150	$0,009 \times d_1$	180	$0,007 \times d_1$	<input type="checkbox"/>	<input type="checkbox"/>	<input type="checkbox"/>	<input checked="" type="checkbox"/>	
5.3											
S	1.1	120	$0,009 \times d_1$	140	$0,010 \times d_1$	150	$0,007 \times d_1$	<input type="checkbox"/>	<input type="checkbox"/>	<input type="checkbox"/>	<input checked="" type="checkbox"/>
	1.2	90	$0,007 \times d_1$	100	$0,008 \times d_1$	120	$0,006 \times d_1$	<input type="checkbox"/>	<input type="checkbox"/>	<input type="checkbox"/>	<input checked="" type="checkbox"/>
	1.3	50	$0,006 \times d_1$	70	$0,007 \times d_1$	90	$0,005 \times d_1$	<input type="checkbox"/>	<input type="checkbox"/>	<input type="checkbox"/>	<input checked="" type="checkbox"/>
	2.1	80	$0,007 \times d_1$	100	$0,008 \times d_1$	110	$0,006 \times d_1$	<input type="checkbox"/>	<input type="checkbox"/>	<input type="checkbox"/>	<input checked="" type="checkbox"/>
	2.2	30	$0,005 \times d_1$	40	$0,006 \times d_1$	50	$0,004 \times d_1$	<input type="checkbox"/>	<input type="checkbox"/>	<input type="checkbox"/>	<input checked="" type="checkbox"/>
	2.3	30	$0,005 \times d_1$	40	$0,006 \times d_1$	50	$0,004 \times d_1$	<input type="checkbox"/>	<input type="checkbox"/>	<input type="checkbox"/>	<input checked="" type="checkbox"/>
	2.4	30	$0,005 \times d_1$	30	$0,006 \times d_1$	40	$0,004 \times d_1$	<input type="checkbox"/>	<input type="checkbox"/>	<input type="checkbox"/>	<input checked="" type="checkbox"/>
2.5	20	$0,005 \times d_1$	30	$0,006 \times d_1$	40	$0,004 \times d_1$	<input type="checkbox"/>	<input type="checkbox"/>	<input type="checkbox"/>	<input checked="" type="checkbox"/>	
2.6	30	$0,005 \times d_1$	30	$0,006 \times d_1$	40	$0,004 \times d_1$	<input type="checkbox"/>	<input type="checkbox"/>	<input type="checkbox"/>	<input checked="" type="checkbox"/>	
H	1.1	160	$0,008 \times d_1$	180	$0,009 \times d_1$	200	$0,010 \times d_1$	<input type="checkbox"/>	<input checked="" type="checkbox"/>	<input type="checkbox"/>	<input type="checkbox"/>
	1.2	120	$0,007 \times d_1$	150	$0,008 \times d_1$	170	$0,009 \times d_1$	<input type="checkbox"/>	<input checked="" type="checkbox"/>	<input type="checkbox"/>	<input type="checkbox"/>
	1.3										
	1.4										
	1.5										

v_c = Schnittgeschwindigkeit · Cutting speed
 f_z = Vorschub pro Zahn · Feed per tooth

■ = sehr gut geeignet · very suitable
□ = gut geeignet · suitable

- Multifunktionales Hochleistungswerkzeug
- Optimierte Querschnitte
- 3 Baulängen verfügbar

- Multi-functional, high performance tool
- Optimised chisel edge
- 3 lengths available

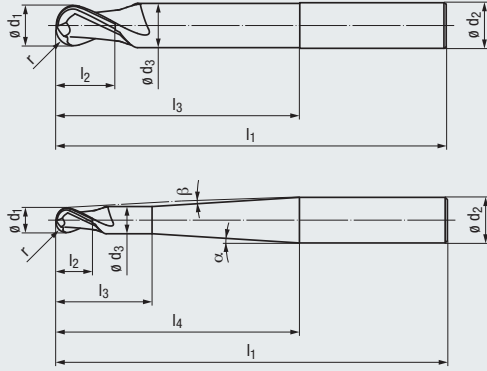

N

HM

DIN 6535
HA
HB

30° Kugel

MMS
MQL

≤ 55 HRC

V_c/f_z
11



new

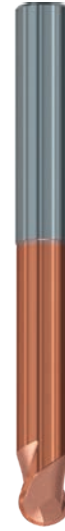

Allround

Beschichtung · Coating

TIALN

Einsatzgebiete – Material (siehe Seite 4)

Applications – material (see page 4)

- In fast allen Werkstoffen einsetzbar
- Zum Schrappen, Schlichten sowie zum HSC-Schlichten geeignet

- For almost all materials
- Suitable for roughing, finishing and HSC finishing

P	1.1-5.1
M	1.1-4.1
K	1.1-4.2
N	2.1-2.8, 5.2 1.2-1.4
S	1.1-1.3 2.1-2.6
H	1.1-1.2

l₃ = 5 x d₁ – Lange Ausführung · Long design

Bestell-Code · Order code

3821A

∅ d ₁	r	l ₂	l ₃	l ₁	∅ d ₃	l ₄	∅ d ₂	α	β	Z	Dimens.-Code		
-0,02	-0,01						h5			(Flutes)			
0,5	0,25	1	2,5	57	0,45	18,2	6	10°	9°	2	.0005	●	
1	0,5	2	5	57	0,95	19,3	6	10°	8°	2	.001	●	
1,5	0,75	2,5	7,5	57	1,4	20,5	6	10°	6,5°	2	.0015	●	
2	1	3	10	63	1,8	21,9	6	10°	5,5°	2	.002	●	
3	1,5	3,5	15	63	2,8	24	6	10°	4°	2	.003	●	
4	2	4	20	63	3,8	26,2	6	10°	2,5°	2	.004	●	
5	2,5	5	25	66	4,7	28,6	6	10°	1,5°	2	.005	●	
6	3	6	30	68	5,6	–	6	–	–	2	.006	●	
8	4	7	40	78	7,6	–	8	–	–	2	.008	●	
10	5	8	50	92	9,6	–	10	–	–	2	.010	●	
12	6	10	60	106	11,5	–	12	–	–	2	.012	●	



Hartmetall-Kugelfräser – lange Ausführung (2-Schneiden)
Solid carbide ball nose end mills – long design (2 flutes)

N

$l_3 = 5 \times d_1$

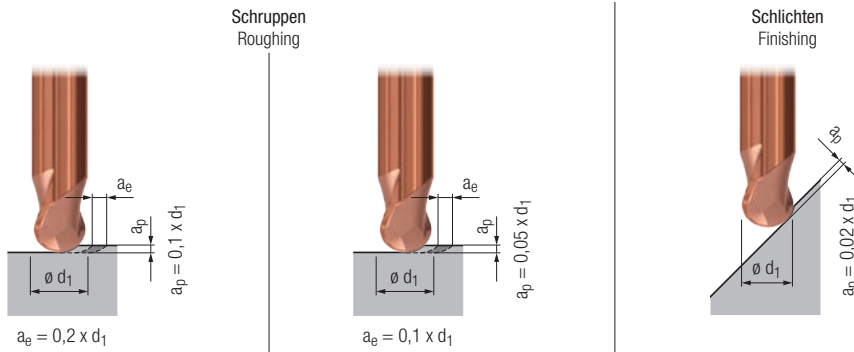

Gültig für · Valid for
3821A

	V_c [m/min]	f_z [mm]	V_c [m/min]	f_z [mm]	V_c [m/min]	f_z [mm]					
									MMS MQL		
P	1.1	240	$0,013 \times d_1$	260	$0,015 \times d_1$	280	$0,013 \times d_1$	<input type="checkbox"/>	<input checked="" type="checkbox"/>	<input type="checkbox"/>	<input checked="" type="checkbox"/>
	2.1	220	$0,012 \times d_1$	240	$0,014 \times d_1$	260	$0,012 \times d_1$	<input type="checkbox"/>	<input checked="" type="checkbox"/>	<input type="checkbox"/>	<input checked="" type="checkbox"/>
	3.1	200	$0,011 \times d_1$	220	$0,013 \times d_1$	240	$0,011 \times d_1$	<input type="checkbox"/>	<input checked="" type="checkbox"/>	<input type="checkbox"/>	<input type="checkbox"/>
	4.1	180	$0,010 \times d_1$	200	$0,012 \times d_1$	220	$0,010 \times d_1$	<input type="checkbox"/>	<input checked="" type="checkbox"/>	<input type="checkbox"/>	<input type="checkbox"/>
	5.1	160	$0,009 \times d_1$	180	$0,010 \times d_1$	200	$0,009 \times d_1$	<input type="checkbox"/>	<input checked="" type="checkbox"/>	<input type="checkbox"/>	<input type="checkbox"/>
M	1.1	120	$0,008 \times d_1$	140	$0,009 \times d_1$	160	$0,010 \times d_1$			<input type="checkbox"/>	<input checked="" type="checkbox"/>
	2.1	100	$0,008 \times d_1$	120	$0,009 \times d_1$	140	$0,010 \times d_1$			<input type="checkbox"/>	<input checked="" type="checkbox"/>
	3.1	80	$0,006 \times d_1$	90	$0,007 \times d_1$	100	$0,008 \times d_1$			<input type="checkbox"/>	<input checked="" type="checkbox"/>
	4.1	70	$0,006 \times d_1$	80	$0,007 \times d_1$	90	$0,008 \times d_1$			<input type="checkbox"/>	<input checked="" type="checkbox"/>
K	1.1	240	$0,011 \times d_1$	260	$0,013 \times d_1$	280	$0,010 \times d_1$	<input type="checkbox"/>	<input checked="" type="checkbox"/>	<input type="checkbox"/>	<input type="checkbox"/>
	1.2	240	$0,011 \times d_1$	260	$0,013 \times d_1$	280	$0,010 \times d_1$	<input type="checkbox"/>	<input checked="" type="checkbox"/>	<input type="checkbox"/>	<input type="checkbox"/>
	2.1	200	$0,011 \times d_1$	220	$0,013 \times d_1$	240	$0,010 \times d_1$	<input type="checkbox"/>	<input checked="" type="checkbox"/>	<input type="checkbox"/>	<input type="checkbox"/>
	2.2	200	$0,011 \times d_1$	220	$0,013 \times d_1$	240	$0,010 \times d_1$	<input type="checkbox"/>	<input checked="" type="checkbox"/>	<input type="checkbox"/>	<input type="checkbox"/>
	3.1	160	$0,010 \times d_1$	180	$0,011 \times d_1$	200	$0,008 \times d_1$	<input type="checkbox"/>	<input checked="" type="checkbox"/>	<input type="checkbox"/>	<input type="checkbox"/>
	3.2	160	$0,010 \times d_1$	180	$0,011 \times d_1$	200	$0,008 \times d_1$	<input type="checkbox"/>	<input checked="" type="checkbox"/>	<input type="checkbox"/>	<input type="checkbox"/>
	4.1	130	$0,008 \times d_1$	140	$0,009 \times d_1$	160	$0,007 \times d_1$	<input type="checkbox"/>	<input checked="" type="checkbox"/>	<input type="checkbox"/>	<input type="checkbox"/>
	4.2	120	$0,008 \times d_1$	130	$0,009 \times d_1$	140	$0,007 \times d_1$	<input type="checkbox"/>	<input checked="" type="checkbox"/>	<input type="checkbox"/>	<input type="checkbox"/>
N	1.1										
	1.2	380	$0,015 \times d_1$	400	$0,017 \times d_1$	420	$0,014 \times d_1$			<input type="checkbox"/>	<input checked="" type="checkbox"/>
	1.3	340	$0,014 \times d_1$	360	$0,016 \times d_1$	380	$0,013 \times d_1$			<input type="checkbox"/>	<input checked="" type="checkbox"/>
	1.4	280	$0,013 \times d_1$	300	$0,015 \times d_1$	320	$0,012 \times d_1$			<input type="checkbox"/>	<input checked="" type="checkbox"/>
	1.5										
	1.6										
	2.1	180	$0,012 \times d_1$	230	$0,012 \times d_1$	260	$0,010 \times d_1$			<input type="checkbox"/>	<input checked="" type="checkbox"/>
	2.2	180	$0,012 \times d_1$	230	$0,012 \times d_1$	260	$0,010 \times d_1$			<input type="checkbox"/>	<input checked="" type="checkbox"/>
	2.3	180	$0,012 \times d_1$	230	$0,012 \times d_1$	260	$0,010 \times d_1$	<input type="checkbox"/>	<input type="checkbox"/>	<input type="checkbox"/>	<input checked="" type="checkbox"/>
	2.4	150	$0,010 \times d_1$	200	$0,010 \times d_1$	220	$0,008 \times d_1$	<input type="checkbox"/>	<input type="checkbox"/>	<input type="checkbox"/>	<input checked="" type="checkbox"/>
	2.5	150	$0,010 \times d_1$	200	$0,010 \times d_1$	220	$0,008 \times d_1$	<input type="checkbox"/>	<input type="checkbox"/>	<input type="checkbox"/>	<input checked="" type="checkbox"/>
	2.6	150	$0,010 \times d_1$	200	$0,010 \times d_1$	220	$0,008 \times d_1$	<input type="checkbox"/>	<input type="checkbox"/>	<input type="checkbox"/>	<input checked="" type="checkbox"/>
	2.7	140	$0,008 \times d_1$	160	$0,008 \times d_1$	180	$0,006 \times d_1$	<input type="checkbox"/>	<input type="checkbox"/>	<input type="checkbox"/>	<input checked="" type="checkbox"/>
	2.8	110	$0,008 \times d_1$	130	$0,008 \times d_1$	140	$0,006 \times d_1$			<input type="checkbox"/>	<input checked="" type="checkbox"/>
	3.1										
	3.2										
4.1											
4.2											
4.3											
4.4											
5.1											
5.2	120	$0,008 \times d_1$	140	$0,009 \times d_1$	160	$0,007 \times d_1$			<input type="checkbox"/>	<input checked="" type="checkbox"/>	
5.3											
S	1.1	110	$0,009 \times d_1$	130	$0,010 \times d_1$	140	$0,007 \times d_1$			<input type="checkbox"/>	<input checked="" type="checkbox"/>
	1.2	80	$0,007 \times d_1$	90	$0,008 \times d_1$	110	$0,006 \times d_1$			<input type="checkbox"/>	<input checked="" type="checkbox"/>
	1.3	40	$0,006 \times d_1$	60	$0,007 \times d_1$	80	$0,005 \times d_1$			<input type="checkbox"/>	<input checked="" type="checkbox"/>
	2.1	80	$0,007 \times d_1$	90	$0,008 \times d_1$	100	$0,006 \times d_1$			<input type="checkbox"/>	<input checked="" type="checkbox"/>
	2.2	30	$0,005 \times d_1$	40	$0,006 \times d_1$	50	$0,004 \times d_1$			<input type="checkbox"/>	<input checked="" type="checkbox"/>
	2.3	30	$0,005 \times d_1$	40	$0,006 \times d_1$	50	$0,004 \times d_1$			<input type="checkbox"/>	<input checked="" type="checkbox"/>
	2.4	20	$0,005 \times d_1$	30	$0,006 \times d_1$	40	$0,004 \times d_1$			<input type="checkbox"/>	<input checked="" type="checkbox"/>
2.5	20	$0,005 \times d_1$	30	$0,006 \times d_1$	40	$0,004 \times d_1$			<input type="checkbox"/>	<input checked="" type="checkbox"/>	
2.6	20	$0,005 \times d_1$	30	$0,006 \times d_1$	40	$0,004 \times d_1$			<input type="checkbox"/>	<input checked="" type="checkbox"/>	
H	1.1	150	$0,008 \times d_1$	170	$0,009 \times d_1$	190	$0,010 \times d_1$	<input type="checkbox"/>	<input checked="" type="checkbox"/>		
	1.2	110	$0,007 \times d_1$	140	$0,008 \times d_1$	160	$0,009 \times d_1$	<input type="checkbox"/>	<input checked="" type="checkbox"/>		
	1.3										
	1.4										
	1.5										

- Multifunktionales Hochleistungswerkzeug
- Optimierte Querschneide
- 3 Baulängen verfügbar

- Multi-functional, high performance tool
- Optimised chisel edge
- 3 lengths available

N

HM

DIN 6535
HA
HB

30° Kugel

MMS
MQL

≤ 55 HRC

V_c/f_z
13



new



Allround

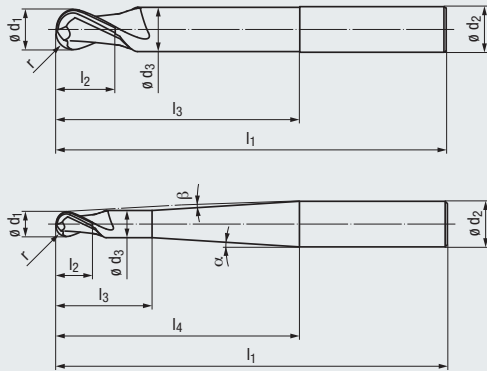

Beschichtung · Coating

TIALN

Einsatzgebiete – Material (siehe Seite 4)

Applications – material (see page 4)

- In fast allen Werkstoffen einsetzbar
- Zum Schruppen, Schlichten sowie zum HSC-Schlichten geeignet

- For almost all materials
- Suitable for roughing, finishing and HSC finishing

P	1.1-5.1
M	1.1-4.1
K	1.1-4.2
N	2.1-2.8, 5.2 1.2-1.4
S	1.1-1.3 2.1-2.6
H	1.1-1.2

$l_3 = 8 \times d_1$ – Extra lange Ausführung · Extra long design

Bestell-Code · Order code												3822A	
$\varnothing d_1$	r	l_2	l_3	l_1	$\varnothing d_3$	l_4	$\varnothing d_2$ h5	α	β	Z (Flutes)	Dimens.- Code		
0,5	0,25	1	4	57	0,45	19,7	6	10°	8°	2	.0005	●	
1	0,5	2	8	60	0,95	22,3	6	10°	6,5°	2	.001	●	
1,5	0,75	2,5	12	63	1,4	25	6	10°	5,5°	2	.0015	●	
2	1	3	16	66	1,8	27,9	6	10°	4,5°	2	.002	●	
3	1,5	3,5	24	72	2,8	33	6	10°	3°	2	.003	●	
4	2	4	32	76	3,8	38,2	6	10°	2°	2	.004	●	
5	2,5	5	40	80	4,7	43,6	6	10°	1°	2	.005	●	
6	3	6	48	86	5,6	–	6	–	–	2	.006	●	
8	4	7	64	102	7,6	–	8	–	–	2	.008	●	



Hartmetall-Kugelfräser – extra lange Ausführung (2-Schneiden)
Solid carbide ball nose end mills – extra long design (2 flutes)

N

$l_3 = 8 \times d_1$

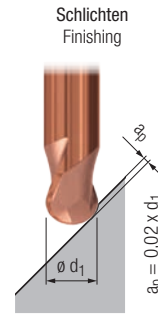
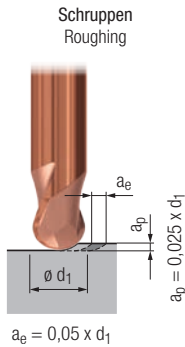

Gültig für · Valid for
3822A

	V_c [m/min]	f_z [mm]	V_c [m/min]	f_z [mm]				
P	1.1	220	$0,013 \times d_1$	240	$0,013 \times d_1$	<input type="checkbox"/>	<input checked="" type="checkbox"/>	<input type="checkbox"/>
	2.1	200	$0,013 \times d_1$	220	$0,013 \times d_1$	<input type="checkbox"/>	<input checked="" type="checkbox"/>	<input type="checkbox"/>
	3.1	180	$0,012 \times d_1$	200	$0,012 \times d_1$	<input type="checkbox"/>	<input checked="" type="checkbox"/>	<input type="checkbox"/>
	4.1	160	$0,012 \times d_1$	180	$0,012 \times d_1$	<input type="checkbox"/>	<input checked="" type="checkbox"/>	<input type="checkbox"/>
	5.1	150	$0,010 \times d_1$	170	$0,010 \times d_1$	<input type="checkbox"/>	<input checked="" type="checkbox"/>	<input type="checkbox"/>
M	1.1	120	$0,008 \times d_1$	140	$0,009 \times d_1$			<input type="checkbox"/>
	2.1	100	$0,008 \times d_1$	120	$0,009 \times d_1$			<input type="checkbox"/>
	3.1	80	$0,006 \times d_1$	90	$0,007 \times d_1$			<input type="checkbox"/>
	4.1	70	$0,006 \times d_1$	80	$0,007 \times d_1$			<input type="checkbox"/>
K	1.1	220	$0,011 \times d_1$	240	$0,013 \times d_1$	<input type="checkbox"/>	<input checked="" type="checkbox"/>	<input type="checkbox"/>
	1.2	220	$0,011 \times d_1$	240	$0,013 \times d_1$	<input type="checkbox"/>	<input checked="" type="checkbox"/>	<input type="checkbox"/>
	2.1	180	$0,011 \times d_1$	200	$0,013 \times d_1$	<input type="checkbox"/>	<input checked="" type="checkbox"/>	<input type="checkbox"/>
	2.2	180	$0,011 \times d_1$	200	$0,013 \times d_1$	<input type="checkbox"/>	<input checked="" type="checkbox"/>	<input type="checkbox"/>
	3.1	150	$0,010 \times d_1$	160	$0,011 \times d_1$	<input type="checkbox"/>	<input checked="" type="checkbox"/>	<input type="checkbox"/>
	3.2	150	$0,010 \times d_1$	160	$0,011 \times d_1$	<input type="checkbox"/>	<input checked="" type="checkbox"/>	<input type="checkbox"/>
	4.1	120	$0,008 \times d_1$	130	$0,009 \times d_1$	<input type="checkbox"/>	<input checked="" type="checkbox"/>	<input type="checkbox"/>
	4.2	110	$0,008 \times d_1$	120	$0,009 \times d_1$	<input type="checkbox"/>	<input checked="" type="checkbox"/>	<input type="checkbox"/>
N	1.1							
	1.2	340	$0,015 \times d_1$	360	$0,017 \times d_1$			<input type="checkbox"/>
	1.3	300	$0,014 \times d_1$	320	$0,016 \times d_1$			<input type="checkbox"/>
	1.4	240	$0,013 \times d_1$	260	$0,015 \times d_1$			<input type="checkbox"/>
	1.5							
	1.6							
	2.1	160	$0,012 \times d_1$	200	$0,012 \times d_1$			<input type="checkbox"/>
	2.2	160	$0,012 \times d_1$	200	$0,012 \times d_1$			<input type="checkbox"/>
	2.3	160	$0,012 \times d_1$	200	$0,012 \times d_1$	<input type="checkbox"/>	<input type="checkbox"/>	<input type="checkbox"/>
	2.4	140	$0,010 \times d_1$	160	$0,010 \times d_1$			<input type="checkbox"/>
	2.5	140	$0,010 \times d_1$	160	$0,010 \times d_1$			<input type="checkbox"/>
	2.6	140	$0,010 \times d_1$	160	$0,010 \times d_1$	<input type="checkbox"/>	<input type="checkbox"/>	<input type="checkbox"/>
	2.7	130	$0,008 \times d_1$	150	$0,008 \times d_1$			<input type="checkbox"/>
	2.8	100	$0,008 \times d_1$	110	$0,008 \times d_1$			<input type="checkbox"/>
	3.1							
	3.2							
4.1								
4.2								
4.3								
4.4								
5.1								
5.2	100	$0,008 \times d_1$	120	$0,009 \times d_1$			<input type="checkbox"/>	
5.3								
S	1.1	90	$0,009 \times d_1$	110	$0,010 \times d_1$			<input type="checkbox"/>
	1.2	70	$0,007 \times d_1$	80	$0,008 \times d_1$			<input type="checkbox"/>
	1.3	30	$0,006 \times d_1$	40	$0,007 \times d_1$			<input type="checkbox"/>
	2.1	90	$0,007 \times d_1$	80	$0,008 \times d_1$			<input type="checkbox"/>
	2.2	70	$0,005 \times d_1$	40	$0,006 \times d_1$			<input type="checkbox"/>
	2.3	30	$0,005 \times d_1$	40	$0,006 \times d_1$			<input type="checkbox"/>
	2.4	20	$0,005 \times d_1$	30	$0,006 \times d_1$			<input type="checkbox"/>
	2.5	20	$0,005 \times d_1$	30	$0,006 \times d_1$			<input type="checkbox"/>
2.6	20	$0,005 \times d_1$	30	$0,006 \times d_1$			<input type="checkbox"/>	
H	1.1	130	$0,008 \times d_1$	150	$0,009 \times d_1$	<input type="checkbox"/>	<input checked="" type="checkbox"/>	
	1.2	100	$0,007 \times d_1$	120	$0,008 \times d_1$	<input type="checkbox"/>	<input checked="" type="checkbox"/>	
	1.3							
	1.4							
	1.5							

v_c = Schnittgeschwindigkeit · Cutting speed
 f_z = Vorschub pro Zahn · Feed per tooth

■ = sehr gut geeignet · very suitable
□ = gut geeignet · suitable

- Multifunktionales Hochleistungswerkzeug
- 2 Schneiden zur Mitte
- Optimierte Querschneide
- 3 Baulängen verfügbar

- Multi-functional, high performance tool
- 2 centre cutting edges
- Optimised chisel edge
- 3 lengths available

N

HM

DIN 6535
HA
HB

30° Kugel

MMS
MQL

≤ 55 HRC

V_c/f_z
15



new



Allround

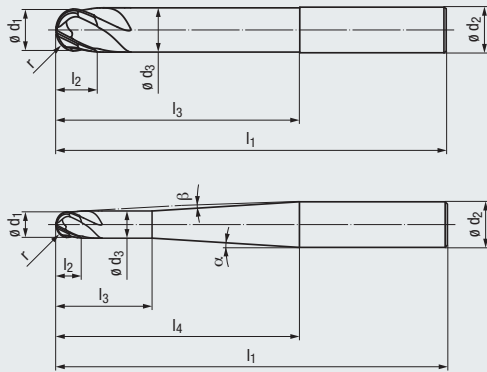

Beschichtung · Coating

TIALN

Einsatzgebiete – Material (siehe Seite 4)

Applications – material (see page 4)

- In fast allen Werkstoffen einsetzbar
- Zum Schruppen, Schlichten sowie zum HSC-Schlichten geeignet

- For almost all materials
- Suitable for roughing, finishing and HSC finishing

P	1.1-5.1
M	1.1-4.1
K	1.1-4.2
N	2.1-2.8, 5.2 1.2-1.4
S	1.1-2.6
H	1.1-1.2

$l_3 = 3 \times d_1$ – Kurze Ausführung · Short design

Bestell-Code · Order code

3823A

$\varnothing d_1$ -0,02	r -0,01	l_2	l_3	l_1	$\varnothing d_3$	l_4	$\varnothing d_2$ h5	α	β	Z (Flutes)	Dimens.- Code		
2	1	3	8	57	1,8	19,9	6	10°	6,5°	4	.002	●	
3	1,5	3,5	10	57	2,8	19	6	10°	5,5°	4	.003	●	
4	2	4	12	57	3,8	18,2	6	10°	3,5°	4	.004	●	
5	2,5	5	15	57	4,7	18,6	6	10°	2°	4	.005	●	
6	3	6	20	57	5,6	–	6	–	–	4	.006	●	
8	4	7	25	63	7,6	–	8	–	–	4	.008	●	
10	5	8	30	72	9,6	–	10	–	–	4	.010	●	
12	6	10	36	83	11,5	–	12	–	–	4	.012	●	



15-90° Alle Schneiden effektiv im Einsatz
All cutting edges in operation

0-15° 2 Schneiden effektiv im Einsatz
2 cutting edges in operation



Hartmetall-Kugelfräser – kurze Ausführung (4 Schneiden)
Solid carbide ball nose end mills – short design (4 flutes)

N

$l_3 = 3 \times d_1$

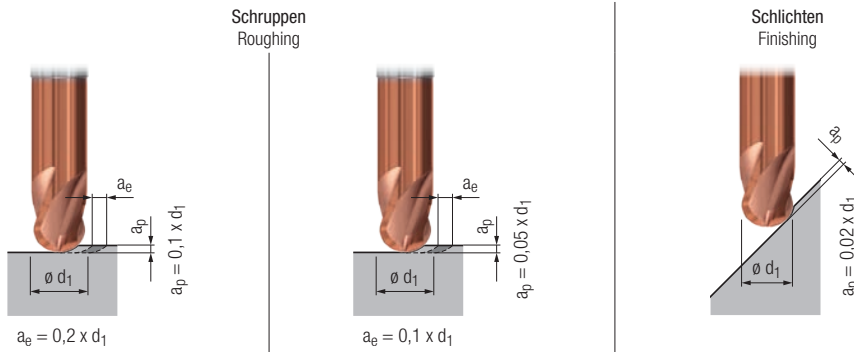

Gültig für · Valid for
3823A

		V_c	f_z	V_c	f_z	V_c	f_z			MMS	MQL	
		[m/min]	[mm]	[m/min]	[mm]	[m/min]	[mm]					
P	1.1	260	$0,013 \times d_1$	280	$0,015 \times d_1$	300	$0,013 \times d_1$	<input type="checkbox"/>	<input checked="" type="checkbox"/>	<input type="checkbox"/>	<input checked="" type="checkbox"/>	
	2.1	240	$0,012 \times d_1$	260	$0,014 \times d_1$	280	$0,012 \times d_1$	<input type="checkbox"/>	<input checked="" type="checkbox"/>	<input type="checkbox"/>	<input checked="" type="checkbox"/>	
	3.1	220	$0,011 \times d_1$	240	$0,013 \times d_1$	260	$0,011 \times d_1$	<input type="checkbox"/>	<input checked="" type="checkbox"/>	<input type="checkbox"/>	<input checked="" type="checkbox"/>	
	4.1	200	$0,010 \times d_1$	220	$0,012 \times d_1$	240	$0,010 \times d_1$	<input type="checkbox"/>	<input checked="" type="checkbox"/>	<input type="checkbox"/>	<input checked="" type="checkbox"/>	
	5.1	180	$0,009 \times d_1$	200	$0,010 \times d_1$	220	$0,009 \times d_1$	<input type="checkbox"/>	<input checked="" type="checkbox"/>	<input type="checkbox"/>	<input checked="" type="checkbox"/>	
M	1.1	140	$0,008 \times d_1$	160	$0,009 \times d_1$	180	$0,010 \times d_1$			<input type="checkbox"/>	<input checked="" type="checkbox"/>	
	2.1	120	$0,008 \times d_1$	140	$0,009 \times d_1$	160	$0,010 \times d_1$			<input type="checkbox"/>	<input checked="" type="checkbox"/>	
	3.1	100	$0,006 \times d_1$	110	$0,007 \times d_1$	120	$0,008 \times d_1$			<input type="checkbox"/>	<input checked="" type="checkbox"/>	
	4.1	80	$0,006 \times d_1$	90	$0,007 \times d_1$	100	$0,008 \times d_1$			<input type="checkbox"/>	<input checked="" type="checkbox"/>	
K	1.1	260	$0,011 \times d_1$	280	$0,013 \times d_1$	300	$0,010 \times d_1$	<input type="checkbox"/>	<input checked="" type="checkbox"/>	<input type="checkbox"/>	<input checked="" type="checkbox"/>	
	1.2	260	$0,011 \times d_1$	280	$0,013 \times d_1$	300	$0,010 \times d_1$	<input type="checkbox"/>	<input checked="" type="checkbox"/>	<input type="checkbox"/>	<input checked="" type="checkbox"/>	
	2.1	220	$0,011 \times d_1$	240	$0,013 \times d_1$	260	$0,010 \times d_1$	<input type="checkbox"/>	<input checked="" type="checkbox"/>	<input type="checkbox"/>	<input checked="" type="checkbox"/>	
	2.2	220	$0,011 \times d_1$	240	$0,013 \times d_1$	260	$0,010 \times d_1$	<input type="checkbox"/>	<input checked="" type="checkbox"/>	<input type="checkbox"/>	<input checked="" type="checkbox"/>	
	3.1	180	$0,010 \times d_1$	200	$0,011 \times d_1$	220	$0,008 \times d_1$	<input type="checkbox"/>	<input checked="" type="checkbox"/>	<input type="checkbox"/>	<input checked="" type="checkbox"/>	
	3.2	180	$0,010 \times d_1$	200	$0,011 \times d_1$	220	$0,008 \times d_1$	<input type="checkbox"/>	<input checked="" type="checkbox"/>	<input type="checkbox"/>	<input checked="" type="checkbox"/>	
	4.1	140	$0,008 \times d_1$	160	$0,009 \times d_1$	180	$0,007 \times d_1$	<input type="checkbox"/>	<input checked="" type="checkbox"/>	<input type="checkbox"/>	<input checked="" type="checkbox"/>	
	4.2	130	$0,008 \times d_1$	140	$0,009 \times d_1$	150	$0,007 \times d_1$	<input type="checkbox"/>	<input checked="" type="checkbox"/>	<input type="checkbox"/>	<input checked="" type="checkbox"/>	
N	1.1											
	1.2	400	$0,015 \times d_1$	420	$0,017 \times d_1$	450	$0,014 \times d_1$			<input type="checkbox"/>	<input checked="" type="checkbox"/>	
	1.3	350	$0,014 \times d_1$	370	$0,016 \times d_1$	400	$0,013 \times d_1$			<input type="checkbox"/>	<input checked="" type="checkbox"/>	
	1.4	280	$0,013 \times d_1$	300	$0,015 \times d_1$	350	$0,012 \times d_1$			<input type="checkbox"/>	<input checked="" type="checkbox"/>	
	1.5											
	1.6											
	2.1	200	$0,012 \times d_1$	260	$0,012 \times d_1$	280	$0,010 \times d_1$			<input type="checkbox"/>	<input checked="" type="checkbox"/>	
	2.2	200	$0,012 \times d_1$	260	$0,012 \times d_1$	280	$0,010 \times d_1$			<input type="checkbox"/>	<input checked="" type="checkbox"/>	
	2.3	200	$0,012 \times d_1$	260	$0,012 \times d_1$	280	$0,010 \times d_1$	<input type="checkbox"/>	<input type="checkbox"/>	<input type="checkbox"/>	<input checked="" type="checkbox"/>	
	2.4	160	$0,010 \times d_1$	220	$0,010 \times d_1$	250	$0,008 \times d_1$	<input type="checkbox"/>	<input type="checkbox"/>	<input type="checkbox"/>	<input checked="" type="checkbox"/>	
	2.5	160	$0,010 \times d_1$	220	$0,010 \times d_1$	250	$0,008 \times d_1$	<input type="checkbox"/>	<input type="checkbox"/>	<input type="checkbox"/>	<input checked="" type="checkbox"/>	
	2.6	160	$0,010 \times d_1$	220	$0,010 \times d_1$	250	$0,008 \times d_1$	<input type="checkbox"/>	<input type="checkbox"/>	<input type="checkbox"/>	<input checked="" type="checkbox"/>	
	2.7	150	$0,008 \times d_1$	180	$0,008 \times d_1$	200	$0,006 \times d_1$	<input type="checkbox"/>	<input type="checkbox"/>	<input type="checkbox"/>	<input checked="" type="checkbox"/>	
	2.8	120	$0,008 \times d_1$	140	$0,008 \times d_1$	160	$0,006 \times d_1$	<input type="checkbox"/>	<input type="checkbox"/>	<input type="checkbox"/>	<input checked="" type="checkbox"/>	
	3.1											
	3.2											
4.1												
4.2												
4.3												
4.4												
5.1												
5.2	130	$0,008 \times d_1$	150	$0,009 \times d_1$	180	$0,007 \times d_1$			<input type="checkbox"/>	<input checked="" type="checkbox"/>		
5.3												
S	1.1	120	$0,009 \times d_1$	140	$0,010 \times d_1$	150	$0,007 \times d_1$			<input type="checkbox"/>	<input checked="" type="checkbox"/>	
	1.2	90	$0,007 \times d_1$	100	$0,008 \times d_1$	120	$0,006 \times d_1$			<input type="checkbox"/>	<input checked="" type="checkbox"/>	
	1.3	50	$0,006 \times d_1$	70	$0,007 \times d_1$	90	$0,005 \times d_1$			<input type="checkbox"/>	<input checked="" type="checkbox"/>	
	2.1	90	$0,007 \times d_1$	100	$0,008 \times d_1$	110	$0,006 \times d_1$			<input type="checkbox"/>	<input checked="" type="checkbox"/>	
	2.2	30	$0,005 \times d_1$	40	$0,006 \times d_1$	50	$0,004 \times d_1$			<input type="checkbox"/>	<input checked="" type="checkbox"/>	
	2.3	30	$0,005 \times d_1$	40	$0,006 \times d_1$	50	$0,004 \times d_1$			<input type="checkbox"/>	<input checked="" type="checkbox"/>	
	2.4	20	$0,005 \times d_1$	30	$0,006 \times d_1$	40	$0,004 \times d_1$			<input type="checkbox"/>	<input checked="" type="checkbox"/>	
	2.5	20	$0,005 \times d_1$	30	$0,006 \times d_1$	40	$0,004 \times d_1$			<input type="checkbox"/>	<input checked="" type="checkbox"/>	
2.6	20	$0,005 \times d_1$	30	$0,006 \times d_1$	40	$0,004 \times d_1$			<input type="checkbox"/>	<input checked="" type="checkbox"/>		
H	1.1	160	$0,008 \times d_1$	180	$0,009 \times d_1$	200	$0,010 \times d_1$	<input type="checkbox"/>	<input checked="" type="checkbox"/>		<input checked="" type="checkbox"/>	
	1.2	120	$0,007 \times d_1$	150	$0,008 \times d_1$	170	$0,009 \times d_1$	<input type="checkbox"/>	<input checked="" type="checkbox"/>		<input checked="" type="checkbox"/>	
	1.3											
	1.4											
	1.5											

v_c = Schnittgeschwindigkeit · Cutting speed
 f_z = Vorschub pro Zahn · Feed per tooth

■ = sehr gut geeignet · very suitable
□ = gut geeignet · suitable

- Multifunktionales Hochleistungswerkzeug
- 2 Schneiden zur Mitte
- Optimierte Querschneide
- 3 Baulängen verfügbar

- Multi-functional, high performance tool
- 2 centre cutting edges
- Optimised chisel edge
- 3 lengths available

N

HM

DIN 6535
HA
HB

30° **Kugel**

MMS
MQL

≤ 55 **HRC**

V_c/f_z
17



NEW

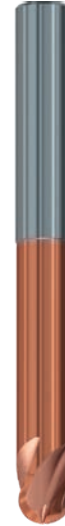

Allround

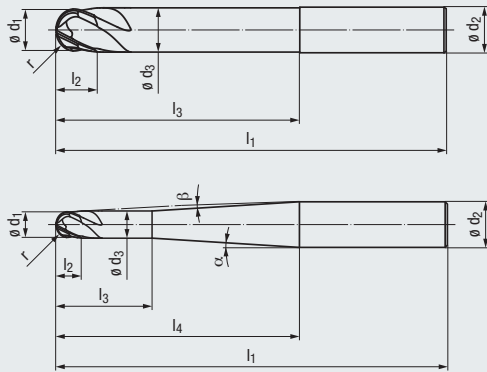

Beschichtung · Coating

TIALN

Einsatzgebiete – Material (siehe Seite 4)

Applications – material (see page 4)

- In fast allen Werkstoffen einsetzbar
- Zum Schrappen, Schlichten sowie zum HSC-Schlichten geeignet

- For almost all materials
- Suitable for roughing, finishing and HSC finishing

P	1.1-5.1
M	1.1-4.1
K	1.1-4.2
N	2.1-2.8, 5.2 1.2-1.4
S	1.1-2.6
H	1.1-1.2

$l_3 = 5 \times d_1$ – Lange Ausführung · Long design

Bestell-Code · Order code

3824A

$\varnothing d_1$ -0,02	r -0,01	l_2	l_3	l_1	$\varnothing d_3$	l_4	$\varnothing d_2$ h5	α	β	Z (Flutes)	Dimens.- Code		
2	1	3	10	63	1,8	21,9	6	10°	5,5°	4	.002	●	
3	1,5	3,5	15	63	2,8	24	6	10°	4°	4	.003	●	
4	2	4	20	63	3,8	26,2	6	10°	2,5°	4	.004	●	
5	2,5	5	25	66	4,7	28,6	6	10°	1,5°	4	.005	●	
6	3	6	30	68	5,6	–	6	–	–	4	.006	●	
8	4	7	40	78	7,6	–	8	–	–	4	.008	●	
10	5	8	50	92	9,6	–	10	–	–	4	.010	●	
12	6	10	60	106	11,5	–	12	–	–	4	.012	●	



15-90° Alle Schneiden effektiv im Einsatz
All cutting edges in operation

0-15° 2 Schneiden effektiv im Einsatz
2 cutting edges in operation



Hartmetall-Kugelfräser – lange Ausführung (4 Schneiden)
Solid carbide ball nose end mills – long design (4 flutes)

N

$l_3 = 5 \times d_1$

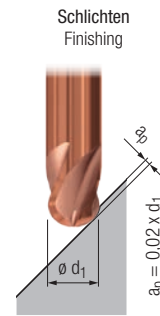
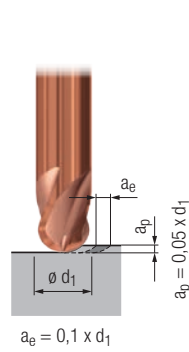
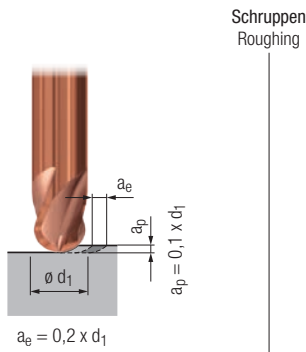

Gültig für · Valid for
3824A

	V_c [m/min]	f_z [mm]	V_c [m/min]	f_z [mm]	V_c [m/min]	f_z [mm]					
									MMS MQL		
P	1.1	240	0,013 x d ₁	260	0,015 x d ₁	280	0,013 x d ₁	<input type="checkbox"/>	<input checked="" type="checkbox"/>	<input type="checkbox"/>	<input checked="" type="checkbox"/>
	2.1	220	0,012 x d ₁	240	0,014 x d ₁	260	0,012 x d ₁	<input type="checkbox"/>	<input checked="" type="checkbox"/>	<input type="checkbox"/>	<input checked="" type="checkbox"/>
	3.1	200	0,011 x d ₁	220	0,013 x d ₁	240	0,011 x d ₁	<input type="checkbox"/>	<input checked="" type="checkbox"/>	<input type="checkbox"/>	<input type="checkbox"/>
	4.1	180	0,010 x d ₁	200	0,012 x d ₁	220	0,010 x d ₁	<input type="checkbox"/>	<input checked="" type="checkbox"/>	<input type="checkbox"/>	<input type="checkbox"/>
	5.1	160	0,009 x d ₁	180	0,010 x d ₁	200	0,009 x d ₁	<input type="checkbox"/>	<input checked="" type="checkbox"/>	<input type="checkbox"/>	<input type="checkbox"/>
M	1.1	120	0,008 x d ₁	140	0,009 x d ₁	160	0,010 x d ₁			<input type="checkbox"/>	<input checked="" type="checkbox"/>
	2.1	100	0,008 x d ₁	120	0,009 x d ₁	140	0,010 x d ₁			<input type="checkbox"/>	<input checked="" type="checkbox"/>
	3.1	80	0,006 x d ₁	90	0,007 x d ₁	100	0,008 x d ₁			<input type="checkbox"/>	<input checked="" type="checkbox"/>
	4.1	70	0,006 x d ₁	80	0,007 x d ₁	90	0,008 x d ₁			<input type="checkbox"/>	<input checked="" type="checkbox"/>
K	1.1	240	0,011 x d ₁	260	0,013 x d ₁	280	0,010 x d ₁	<input type="checkbox"/>	<input checked="" type="checkbox"/>	<input type="checkbox"/>	<input type="checkbox"/>
	1.2	240	0,011 x d ₁	260	0,013 x d ₁	280	0,010 x d ₁	<input type="checkbox"/>	<input checked="" type="checkbox"/>	<input type="checkbox"/>	<input type="checkbox"/>
	2.1	200	0,011 x d ₁	220	0,013 x d ₁	240	0,010 x d ₁	<input type="checkbox"/>	<input checked="" type="checkbox"/>	<input type="checkbox"/>	<input type="checkbox"/>
	2.2	200	0,011 x d ₁	220	0,013 x d ₁	240	0,010 x d ₁	<input type="checkbox"/>	<input checked="" type="checkbox"/>	<input type="checkbox"/>	<input type="checkbox"/>
	3.1	160	0,010 x d ₁	180	0,011 x d ₁	200	0,008 x d ₁	<input type="checkbox"/>	<input checked="" type="checkbox"/>	<input type="checkbox"/>	<input type="checkbox"/>
	3.2	160	0,010 x d ₁	180	0,011 x d ₁	200	0,008 x d ₁	<input type="checkbox"/>	<input checked="" type="checkbox"/>	<input type="checkbox"/>	<input type="checkbox"/>
	4.1	130	0,008 x d ₁	140	0,009 x d ₁	160	0,007 x d ₁	<input type="checkbox"/>	<input checked="" type="checkbox"/>	<input type="checkbox"/>	<input type="checkbox"/>
	4.2	120	0,008 x d ₁	130	0,009 x d ₁	140	0,007 x d ₁	<input type="checkbox"/>	<input checked="" type="checkbox"/>	<input type="checkbox"/>	<input type="checkbox"/>
N	1.1										
	1.2	380	0,015 x d ₁	400	0,017 x d ₁	420	0,014 x d ₁			<input type="checkbox"/>	<input checked="" type="checkbox"/>
	1.3	340	0,014 x d ₁	360	0,016 x d ₁	380	0,013 x d ₁			<input type="checkbox"/>	<input checked="" type="checkbox"/>
	1.4	280	0,013 x d ₁	300	0,015 x d ₁	320	0,012 x d ₁			<input type="checkbox"/>	<input checked="" type="checkbox"/>
	1.5										
	1.6										
	2.1	180	0,012 x d ₁	230	0,012 x d ₁	260	0,010 x d ₁			<input type="checkbox"/>	<input checked="" type="checkbox"/>
	2.2	180	0,012 x d ₁	230	0,012 x d ₁	260	0,010 x d ₁			<input type="checkbox"/>	<input checked="" type="checkbox"/>
	2.3	180	0,012 x d ₁	230	0,012 x d ₁	260	0,010 x d ₁	<input type="checkbox"/>	<input type="checkbox"/>	<input type="checkbox"/>	<input checked="" type="checkbox"/>
	2.4	150	0,010 x d ₁	200	0,010 x d ₁	220	0,008 x d ₁	<input type="checkbox"/>	<input type="checkbox"/>	<input type="checkbox"/>	<input checked="" type="checkbox"/>
	2.5	150	0,010 x d ₁	200	0,010 x d ₁	220	0,008 x d ₁	<input type="checkbox"/>	<input type="checkbox"/>	<input type="checkbox"/>	<input checked="" type="checkbox"/>
	2.6	150	0,010 x d ₁	200	0,010 x d ₁	220	0,008 x d ₁	<input type="checkbox"/>	<input type="checkbox"/>	<input type="checkbox"/>	<input checked="" type="checkbox"/>
	2.7	140	0,008 x d ₁	160	0,008 x d ₁	180	0,006 x d ₁	<input type="checkbox"/>	<input type="checkbox"/>	<input type="checkbox"/>	<input checked="" type="checkbox"/>
	2.8	110	0,008 x d ₁	130	0,008 x d ₁	140	0,006 x d ₁			<input type="checkbox"/>	<input checked="" type="checkbox"/>
	3.1										
	3.2										
4.1											
4.2											
4.3											
4.4											
5.1											
5.2	120	0,008 x d ₁	140	0,009 x d ₁	160	0,007 x d ₁			<input type="checkbox"/>	<input checked="" type="checkbox"/>	
5.3											
S	1.1	110	0,009 x d ₁	130	0,010 x d ₁	140	0,007 x d ₁			<input type="checkbox"/>	<input checked="" type="checkbox"/>
	1.2	80	0,007 x d ₁	90	0,008 x d ₁	110	0,006 x d ₁			<input type="checkbox"/>	<input checked="" type="checkbox"/>
	1.3	40	0,006 x d ₁	60	0,007 x d ₁	80	0,005 x d ₁			<input type="checkbox"/>	<input checked="" type="checkbox"/>
	2.1	80	0,007 x d ₁	90	0,008 x d ₁	100	0,006 x d ₁			<input type="checkbox"/>	<input checked="" type="checkbox"/>
	2.2	30	0,005 x d ₁	40	0,006 x d ₁	50	0,004 x d ₁			<input type="checkbox"/>	<input checked="" type="checkbox"/>
	2.3	30	0,005 x d ₁	40	0,006 x d ₁	50	0,004 x d ₁			<input type="checkbox"/>	<input checked="" type="checkbox"/>
	2.4	20	0,005 x d ₁	30	0,006 x d ₁	40	0,004 x d ₁			<input type="checkbox"/>	<input checked="" type="checkbox"/>
	2.5	20	0,005 x d ₁	30	0,006 x d ₁	40	0,004 x d ₁			<input type="checkbox"/>	<input checked="" type="checkbox"/>
2.6	20	0,005 x d ₁	30	0,006 x d ₁	40	0,004 x d ₁			<input type="checkbox"/>	<input checked="" type="checkbox"/>	
H	1.1	150	0,008 x d ₁	170	0,009 x d ₁	190	0,010 x d ₁	<input type="checkbox"/>	<input checked="" type="checkbox"/>		
	1.2	110	0,007 x d ₁	140	0,008 x d ₁	160	0,009 x d ₁	<input type="checkbox"/>	<input checked="" type="checkbox"/>		
	1.3										
	1.4										
	1.5										

- Multifunktionales Hochleistungswerkzeug
- 2 Schneiden zur Mitte
- Optimierte Querschnitte
- 3 Baulängen verfügbar

- Multi-functional, high performance tool
- 2 centre cutting edges
- Optimised chisel edge
- 3 lengths available

N

HM

DIN 6535
HA
HB

30° Kugel

MMS
MQL

≤ 55
HRC

V_c/f_z
19



new



Allround

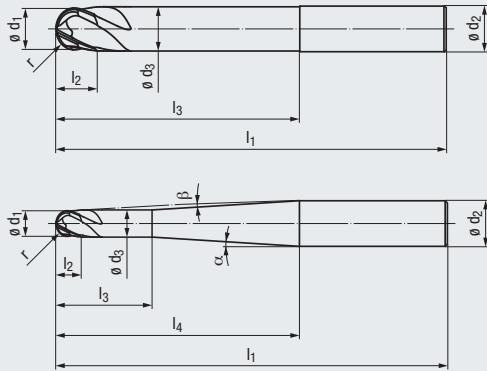

Beschichtung · Coating

TIALN

Einsatzgebiete – Material (siehe Seite 4)

- In fast allen Werkstoffen einsetzbar
- Zum Schrappen, Schlichten sowie zum HSC-Schlichten geeignet

Applications – material (see page 4)

- For almost all materials
- Suitable for roughing, finishing and HSC finishing

P 1.1-5.1

M 1.1-4.1

K 1.1-4.2

N 2.1-2.8, 5.2 1.2-1.4

S 1.1-2.6

H 1.1-1.2

$l_3 = 8 \times d_1$ – Extra lange Ausführung · Extra long design

Bestell-Code · Order code

3825A

$\varnothing d_1$	r	l_2	l_3	l_1	$\varnothing d_3$	l_4	$\varnothing d_2$ h5	α	β	Z (Flutes)	Dimens.- Code	
-0,02	-0,01											
2	1	3	16	66	1,8	27,9	6	10°	4,5°	4	.002	●
3	1,5	3,5	24	72	2,8	33	6	10°	3°	4	.003	●
4	2	4	32	76	3,8	38,2	6	10°	2°	4	.004	●
5	2,5	5	40	80	4,7	43,6	6	10°	1°	4	.005	●
6	3	6	48	86	5,6	–	6	–	–	4	.006	●
8	4	7	64	102	7,6	–	8	–	–	4	.008	●



15-90° Alle Schneiden effektiv im Einsatz
All cutting edges in operation

0-15° 2 Schneiden effektiv im Einsatz
2 cutting edges in operation



Hartmetall-Kugelfräser – extra lange Ausführung (4 Schneiden)
Solid carbide ball nose end mills – extra long design (4 flutes)

N

$l_3 = 8 \times d_1$

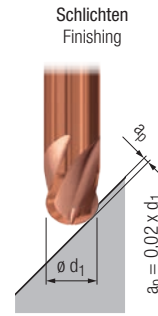
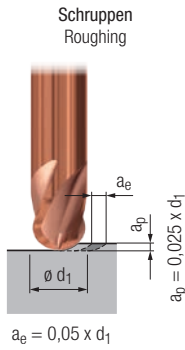

Gültig für · Valid for
3825A

	V_c [m/min]	f_z [mm]	V_c [m/min]	f_z [mm]			MMS MQL	
P	1.1	170	$0,011 \times d_1$	180	$0,011 \times d_1$	<input type="checkbox"/>	<input checked="" type="checkbox"/>	<input type="checkbox"/>
	2.1	150	$0,011 \times d_1$	160	$0,011 \times d_1$	<input type="checkbox"/>	<input checked="" type="checkbox"/>	<input type="checkbox"/>
	3.1	130	$0,010 \times d_1$	140	$0,010 \times d_1$	<input type="checkbox"/>	<input checked="" type="checkbox"/>	<input type="checkbox"/>
	4.1	130	$0,010 \times d_1$	140	$0,010 \times d_1$	<input type="checkbox"/>	<input checked="" type="checkbox"/>	<input type="checkbox"/>
	5.1	120	$0,009 \times d_1$	130	$0,009 \times d_1$	<input type="checkbox"/>	<input checked="" type="checkbox"/>	<input type="checkbox"/>
M	1.1	120	$0,008 \times d_1$	130	$0,009 \times d_1$			<input type="checkbox"/>
	2.1	100	$0,008 \times d_1$	110	$0,009 \times d_1$			<input type="checkbox"/>
	3.1	80	$0,006 \times d_1$	90	$0,007 \times d_1$			<input type="checkbox"/>
	4.1	70	$0,006 \times d_1$	80	$0,007 \times d_1$			<input type="checkbox"/>
K	1.1	200	$0,011 \times d_1$	220	$0,013 \times d_1$	<input type="checkbox"/>	<input checked="" type="checkbox"/>	<input type="checkbox"/>
	1.2	200	$0,011 \times d_1$	220	$0,013 \times d_1$	<input type="checkbox"/>	<input checked="" type="checkbox"/>	<input type="checkbox"/>
	2.1	170	$0,011 \times d_1$	190	$0,013 \times d_1$	<input type="checkbox"/>	<input checked="" type="checkbox"/>	<input type="checkbox"/>
	2.2	170	$0,011 \times d_1$	190	$0,013 \times d_1$	<input type="checkbox"/>	<input checked="" type="checkbox"/>	<input type="checkbox"/>
	3.1	150	$0,010 \times d_1$	160	$0,011 \times d_1$	<input type="checkbox"/>	<input checked="" type="checkbox"/>	<input type="checkbox"/>
	3.2	150	$0,010 \times d_1$	160	$0,011 \times d_1$	<input type="checkbox"/>	<input checked="" type="checkbox"/>	<input type="checkbox"/>
	4.1	120	$0,008 \times d_1$	130	$0,009 \times d_1$	<input type="checkbox"/>	<input checked="" type="checkbox"/>	<input type="checkbox"/>
	4.2	110	$0,008 \times d_1$	120	$0,009 \times d_1$	<input type="checkbox"/>	<input checked="" type="checkbox"/>	<input type="checkbox"/>
N	1.1							
	1.2	340	$0,015 \times d_1$	360	$0,017 \times d_1$			<input type="checkbox"/>
	1.3	300	$0,014 \times d_1$	320	$0,016 \times d_1$			<input type="checkbox"/>
	1.4	240	$0,013 \times d_1$	260	$0,015 \times d_1$			<input type="checkbox"/>
	1.5							
	1.6							
	2.1	160	$0,012 \times d_1$	200	$0,012 \times d_1$			<input type="checkbox"/>
	2.2	160	$0,012 \times d_1$	200	$0,012 \times d_1$			<input type="checkbox"/>
	2.3	160	$0,012 \times d_1$	200	$0,012 \times d_1$	<input type="checkbox"/>	<input type="checkbox"/>	<input type="checkbox"/>
	2.4	140	$0,010 \times d_1$	160	$0,010 \times d_1$			<input type="checkbox"/>
	2.5	140	$0,010 \times d_1$	160	$0,010 \times d_1$			<input type="checkbox"/>
	2.6	140	$0,010 \times d_1$	160	$0,010 \times d_1$	<input type="checkbox"/>	<input type="checkbox"/>	<input type="checkbox"/>
	2.7	130	$0,008 \times d_1$	150	$0,008 \times d_1$			<input type="checkbox"/>
	2.8	100	$0,008 \times d_1$	110	$0,008 \times d_1$			<input type="checkbox"/>
	3.1							
	3.2							
4.1								
4.2								
4.3								
4.4								
5.1								
5.2	100	$0,008 \times d_1$	120	$0,009 \times d_1$			<input type="checkbox"/>	
5.3								
S	1.1	90	$0,009 \times d_1$	110	$0,010 \times d_1$			<input type="checkbox"/>
	1.2	70	$0,007 \times d_1$	80	$0,008 \times d_1$			<input type="checkbox"/>
	1.3	30	$0,006 \times d_1$	40	$0,007 \times d_1$			<input type="checkbox"/>
	2.1	70	$0,007 \times d_1$	80	$0,008 \times d_1$			<input type="checkbox"/>
	2.2	25	$0,005 \times d_1$	40	$0,006 \times d_1$			<input type="checkbox"/>
	2.3	25	$0,005 \times d_1$	40	$0,006 \times d_1$			<input type="checkbox"/>
	2.4	25	$0,005 \times d_1$	30	$0,006 \times d_1$			<input type="checkbox"/>
	2.5	25	$0,005 \times d_1$	30	$0,006 \times d_1$			<input type="checkbox"/>
2.6	20	$0,005 \times d_1$	30	$0,006 \times d_1$			<input type="checkbox"/>	
H	1.1	120	$0,008 \times d_1$	130	$0,009 \times d_1$	<input type="checkbox"/>	<input checked="" type="checkbox"/>	
	1.2	100	$0,007 \times d_1$	110	$0,008 \times d_1$	<input type="checkbox"/>	<input checked="" type="checkbox"/>	
	1.3							
	1.4							
	1.5							

v_c = Schnittgeschwindigkeit · Cutting speed
 f_z = Vorschub pro Zahn · Feed per tooth

■ = sehr gut geeignet · very suitable
□ = gut geeignet · suitable

- Multifunktionales Hochleistungswerkzeug
- 2 Schneiden zur Mitte
- 3 Baulängen verfügbar
- Mit langer Umfangsschneide (min. 1,5 x d₁)

- Multi-functional, high performance tool
- 2 centre cutting edges
- 3 lengths available
- with long peripheral cutting edge (min. 1.5 x d₁)

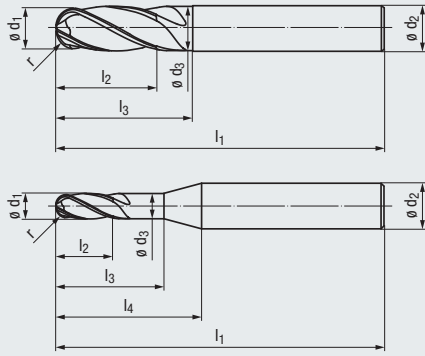

N

HM

DIN 6535
HA
HB

35-38° Kugel

3-5°

MMS
MQL

V_c/f_z
21



new



Allround

Beschichtung · Coating

TIALN

Einsatzgebiete – Material (siehe Seite 4)

- In fast allen Werkstoffen einsetzbar
- Zum HSC-Schlichten geeignet
- Auch zum Besäumen geeignet

Applications – material (see page 4)

- For almost all materials
- Suitable for HSC finishing
- Also suitable for trimming

P	1.1-5.1	
M	1.1-2.1	3.1-4.1
K	1.1-2.2	3.1-4.2
N	2.1-2.8, 4.1-4.2	
N	5.2-5.3	
S	1.1-2.6	

Kurze Ausführung · Short design

Bestell-Code · Order code

3840A

ø d ₁ f8	r	l ₂	l ₃	l ₁	ø d ₃	l ₄	ø d ₂ h5	Z (Flutes)	Dimens.- Code	
3	1,5	5	9	50	2,9	14	6	3	.003	●
4	2	8	12	54	3,8	18	6	3	.004	●
5	2,5	9	16	54	4,8	18	6	3	.005	●
6	3	10	16	54	5,8	–	6	4	.006	●
8	4	12	20	58	7,7	–	8	4	.008	●
10	5	15	24	66	9,5	–	10	4	.010	●
12	6	18	26	73	11,5	–	12	4	.012	●
16	8	24	32	82	15,5	–	16	4	.016	●



15-90° Alle Schneiden effektiv im Einsatz
All cutting edges in operation

0-15° 2 Schneiden effektiv im Einsatz
2 cutting edges in operation



Hartmetall-Kugelfräser – kurze Ausführung
Solid carbide ball nose end mills – short design

N

Gültig für · Valid for
3840A

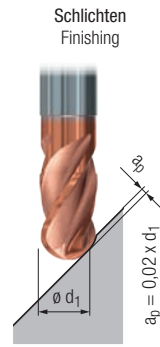
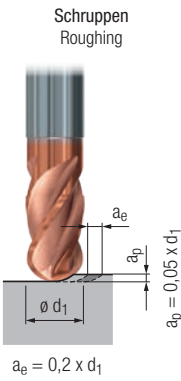

	V_c [m/min]	f_z [mm]	V_c [m/min]	f_z [mm]			MMS MQL		
P	1.1	200	$0,014 \times d_1$	270	$0,010 \times d_1$	<input type="checkbox"/>	<input checked="" type="checkbox"/>	<input type="checkbox"/>	<input checked="" type="checkbox"/>
	2.1	170	$0,013 \times d_1$	230	$0,009 \times d_1$	<input type="checkbox"/>	<input checked="" type="checkbox"/>	<input type="checkbox"/>	<input checked="" type="checkbox"/>
	3.1	140	$0,011 \times d_1$	200	$0,008 \times d_1$	<input type="checkbox"/>	<input checked="" type="checkbox"/>	<input type="checkbox"/>	<input type="checkbox"/>
	4.1	110	$0,010 \times d_1$	160	$0,007 \times d_1$	<input type="checkbox"/>	<input checked="" type="checkbox"/>	<input type="checkbox"/>	<input type="checkbox"/>
	5.1	100	$0,008 \times d_1$	130	$0,006 \times d_1$	<input type="checkbox"/>	<input checked="" type="checkbox"/>	<input type="checkbox"/>	<input type="checkbox"/>
M	1.1	100	$0,008 \times d_1$	130	$0,006 \times d_1$			<input type="checkbox"/>	<input checked="" type="checkbox"/>
	2.1	80	$0,008 \times d_1$	110	$0,006 \times d_1$			<input type="checkbox"/>	<input checked="" type="checkbox"/>
	3.1	60	$0,006 \times d_1$	80	$0,005 \times d_1$			<input type="checkbox"/>	<input checked="" type="checkbox"/>
	4.1	40	$0,006 \times d_1$	60	$0,005 \times d_1$			<input type="checkbox"/>	<input checked="" type="checkbox"/>
K	1.1	200	$0,014 \times d_1$	270	$0,010 \times d_1$	<input type="checkbox"/>	<input checked="" type="checkbox"/>	<input type="checkbox"/>	<input type="checkbox"/>
	1.2	200	$0,014 \times d_1$	270	$0,010 \times d_1$	<input type="checkbox"/>	<input checked="" type="checkbox"/>	<input type="checkbox"/>	<input type="checkbox"/>
	2.1	180	$0,011 \times d_1$	230	$0,008 \times d_1$	<input type="checkbox"/>	<input checked="" type="checkbox"/>	<input type="checkbox"/>	<input type="checkbox"/>
	2.2	180	$0,011 \times d_1$	230	$0,008 \times d_1$	<input type="checkbox"/>	<input checked="" type="checkbox"/>	<input type="checkbox"/>	<input type="checkbox"/>
	3.1	140	$0,011 \times d_1$	200	$0,008 \times d_1$	<input type="checkbox"/>	<input checked="" type="checkbox"/>	<input type="checkbox"/>	<input type="checkbox"/>
	3.2	140	$0,011 \times d_1$	200	$0,008 \times d_1$	<input type="checkbox"/>	<input checked="" type="checkbox"/>	<input type="checkbox"/>	<input type="checkbox"/>
	4.1	110	$0,008 \times d_1$	160	$0,006 \times d_1$	<input type="checkbox"/>	<input checked="" type="checkbox"/>	<input type="checkbox"/>	<input type="checkbox"/>
	4.2	100	$0,008 \times d_1$	130	$0,006 \times d_1$	<input type="checkbox"/>	<input checked="" type="checkbox"/>	<input type="checkbox"/>	<input type="checkbox"/>
N	1.1								
	1.2								
	1.3								
	1.4								
	1.5								
	1.6								
	2.1	180	$0,014 \times d_1$	230	$0,010 \times d_1$			<input type="checkbox"/>	<input checked="" type="checkbox"/>
	2.2	180	$0,014 \times d_1$	230	$0,010 \times d_1$			<input type="checkbox"/>	<input checked="" type="checkbox"/>
	2.3	180	$0,014 \times d_1$	230	$0,010 \times d_1$	<input type="checkbox"/>	<input type="checkbox"/>	<input type="checkbox"/>	<input checked="" type="checkbox"/>
	2.4	140	$0,011 \times d_1$	200	$0,008 \times d_1$			<input type="checkbox"/>	<input checked="" type="checkbox"/>
	2.5	140	$0,011 \times d_1$	200	$0,008 \times d_1$			<input type="checkbox"/>	<input checked="" type="checkbox"/>
	2.6	140	$0,011 \times d_1$	200	$0,008 \times d_1$	<input type="checkbox"/>	<input type="checkbox"/>	<input type="checkbox"/>	<input checked="" type="checkbox"/>
	2.7	90	$0,008 \times d_1$	120	$0,006 \times d_1$			<input type="checkbox"/>	<input checked="" type="checkbox"/>
	2.8	90	$0,008 \times d_1$	120	$0,006 \times d_1$			<input type="checkbox"/>	<input checked="" type="checkbox"/>
	3.1								
	3.2								
4.1	290	$0,020 \times d_1$	400	$0,015 \times d_1$			<input type="checkbox"/>	<input checked="" type="checkbox"/>	
4.2	430	$0,020 \times d_1$	580	$0,015 \times d_1$			<input type="checkbox"/>	<input checked="" type="checkbox"/>	
4.3									
4.4									
5.1									
5.2	100	$0,008 \times d_1$	130	$0,006 \times d_1$			<input type="checkbox"/>	<input checked="" type="checkbox"/>	
5.3	180	$0,017 \times d_1$	270	$0,012 \times d_1$	<input type="checkbox"/>	<input checked="" type="checkbox"/>		<input checked="" type="checkbox"/>	
S	1.1	100	$0,010 \times d_1$	130	$0,007 \times d_1$			<input type="checkbox"/>	<input checked="" type="checkbox"/>
	1.2	80	$0,008 \times d_1$	110	$0,006 \times d_1$			<input type="checkbox"/>	<input checked="" type="checkbox"/>
	1.3	40	$0,007 \times d_1$	60	$0,005 \times d_1$			<input type="checkbox"/>	<input checked="" type="checkbox"/>
	2.1	70	$0,008 \times d_1$	100	$0,006 \times d_1$			<input type="checkbox"/>	<input checked="" type="checkbox"/>
	2.2	25	$0,006 \times d_1$	40	$0,004 \times d_1$			<input type="checkbox"/>	<input checked="" type="checkbox"/>
	2.3	25	$0,006 \times d_1$	30	$0,004 \times d_1$			<input type="checkbox"/>	<input checked="" type="checkbox"/>
	2.4	25	$0,006 \times d_1$	30	$0,004 \times d_1$			<input type="checkbox"/>	<input checked="" type="checkbox"/>
2.5	15	$0,006 \times d_1$	25	$0,004 \times d_1$			<input type="checkbox"/>	<input checked="" type="checkbox"/>	
2.6	25	$0,006 \times d_1$	30	$0,004 \times d_1$			<input type="checkbox"/>	<input checked="" type="checkbox"/>	
H	1.1								
	1.2								
	1.3								
	1.4								
	1.5								

v_c = Schnittgeschwindigkeit · Cutting speed
 f_z = Vorschub pro Zahn · Feed per tooth

■ = sehr gut geeignet · very suitable
□ = gut geeignet · suitable

- Multifunktionales Hochleistungswerkzeug
- 2 Schneiden zur Mitte
- 3 Baulängen verfügbar
- Mit langer Umfangsschneide (min. $2 \times d_1$)

- Multi-functional, high performance tool
- 2 centre cutting edges
- 3 lengths available
- with long peripheral cutting edge (min. $2 \times d_1$)

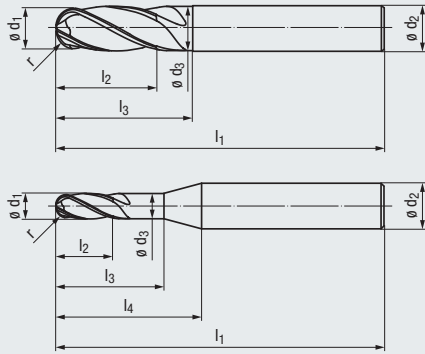

N

HM

DIN 6535
HA
HB

35-38° Kugel

3-5°

MMS
MQL

V_c/f_z
23



Allround

Beschichtung · Coating

TIALN

Einsatzgebiete – Material (siehe Seite 4)

- In fast allen Werkstoffen einsetzbar
- Zum HSC-Schlichten geeignet
- Auch zum Besäumen geeignet

Applications – material (see page 4)

- For almost all materials
- Suitable for HSC finishing
- Also suitable for trimming

P	1.1-5.1	
M	1.1-2.1	3.1-4.1
K	1.1-2.2	3.1-4.2
N	2.1-2.8, 4.1-4.2	
N	5.2-5.3	
S	1.1-2.6	

Lange Ausführung · Long design

Bestell-Code · Order code

2502A

$\varnothing d_1$ f8	r	l_2	l_3	l_1	$\varnothing d_3$	l_4	$\varnothing d_2$ h6	Z (Flutes)	Dimens.- Code		
2	1	6	10	57	1,9	20	6	3	.002	●	
3	1,5	8	14	57	2,9	20	6	3	.003	●	
4	2	11	18	57	3,8	20	6	3	.004	●	
5	2,5	13	19	57	4,8	20	6	3	.005	●	
6	3	13	20	57	5,8	–	6	4	.006	●	
8	4	19	25	63	7,7	–	8	4	.008	●	
10	5	22	30	72	9,5	–	10	4	.010	●	
12	6	26	35	83	11,5	–	12	4	.012	●	
16	8	32	40	92	15,5	–	16	4	.016	●	



15-90° Alle Schneiden effektiv im Einsatz
All cutting edges in operation

0-15° 2 Schneiden effektiv im Einsatz
2 cutting edges in operation



Hartmetall-Kugelfräser – lange Ausführung
Solid carbide ball nose end mills – long design

N

Gültig für · Valid for
2502A

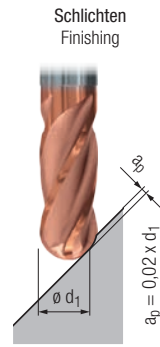
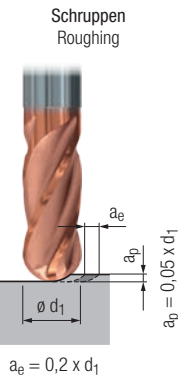

	V_c [m/min]	f_z [mm]	V_c [m/min]	f_z [mm]			MMS MQL		
P	1.1	200	$0,014 \times d_1$	270	$0,010 \times d_1$	<input type="checkbox"/>	<input checked="" type="checkbox"/>	<input type="checkbox"/>	<input checked="" type="checkbox"/>
	2.1	170	$0,013 \times d_1$	230	$0,009 \times d_1$	<input type="checkbox"/>	<input checked="" type="checkbox"/>	<input type="checkbox"/>	<input checked="" type="checkbox"/>
	3.1	140	$0,011 \times d_1$	200	$0,008 \times d_1$	<input type="checkbox"/>	<input checked="" type="checkbox"/>	<input type="checkbox"/>	<input type="checkbox"/>
	4.1	110	$0,010 \times d_1$	160	$0,007 \times d_1$	<input type="checkbox"/>	<input checked="" type="checkbox"/>	<input type="checkbox"/>	<input type="checkbox"/>
	5.1	100	$0,008 \times d_1$	130	$0,006 \times d_1$	<input type="checkbox"/>	<input checked="" type="checkbox"/>	<input type="checkbox"/>	<input type="checkbox"/>
M	1.1	100	$0,008 \times d_1$	130	$0,006 \times d_1$			<input type="checkbox"/>	<input checked="" type="checkbox"/>
	2.1	80	$0,008 \times d_1$	110	$0,006 \times d_1$			<input type="checkbox"/>	<input checked="" type="checkbox"/>
	3.1	60	$0,006 \times d_1$	80	$0,005 \times d_1$			<input type="checkbox"/>	<input checked="" type="checkbox"/>
	4.1	40	$0,006 \times d_1$	60	$0,005 \times d_1$			<input type="checkbox"/>	<input checked="" type="checkbox"/>
K	1.1	200	$0,014 \times d_1$	270	$0,010 \times d_1$	<input type="checkbox"/>	<input checked="" type="checkbox"/>	<input type="checkbox"/>	<input type="checkbox"/>
	1.2	200	$0,014 \times d_1$	270	$0,010 \times d_1$	<input type="checkbox"/>	<input checked="" type="checkbox"/>	<input type="checkbox"/>	<input type="checkbox"/>
	2.1	180	$0,011 \times d_1$	230	$0,008 \times d_1$	<input type="checkbox"/>	<input checked="" type="checkbox"/>	<input type="checkbox"/>	<input type="checkbox"/>
	2.2	180	$0,011 \times d_1$	230	$0,008 \times d_1$	<input type="checkbox"/>	<input checked="" type="checkbox"/>	<input type="checkbox"/>	<input type="checkbox"/>
	3.1	140	$0,011 \times d_1$	200	$0,008 \times d_1$	<input type="checkbox"/>	<input checked="" type="checkbox"/>	<input type="checkbox"/>	<input type="checkbox"/>
	3.2	140	$0,011 \times d_1$	200	$0,008 \times d_1$	<input type="checkbox"/>	<input checked="" type="checkbox"/>	<input type="checkbox"/>	<input type="checkbox"/>
	4.1	110	$0,008 \times d_1$	160	$0,006 \times d_1$	<input type="checkbox"/>	<input checked="" type="checkbox"/>	<input type="checkbox"/>	<input type="checkbox"/>
	4.2	100	$0,008 \times d_1$	130	$0,006 \times d_1$	<input type="checkbox"/>	<input checked="" type="checkbox"/>	<input type="checkbox"/>	<input type="checkbox"/>
N	1.1								
	1.2								
	1.3								
	1.4								
	1.5								
	1.6								
	2.1	180	$0,014 \times d_1$	230	$0,010 \times d_1$			<input type="checkbox"/>	<input checked="" type="checkbox"/>
	2.2	180	$0,014 \times d_1$	230	$0,010 \times d_1$			<input type="checkbox"/>	<input checked="" type="checkbox"/>
	2.3	180	$0,014 \times d_1$	230	$0,010 \times d_1$	<input type="checkbox"/>	<input type="checkbox"/>	<input type="checkbox"/>	<input checked="" type="checkbox"/>
	2.4	140	$0,011 \times d_1$	200	$0,008 \times d_1$			<input type="checkbox"/>	<input checked="" type="checkbox"/>
	2.5	140	$0,011 \times d_1$	200	$0,008 \times d_1$			<input type="checkbox"/>	<input checked="" type="checkbox"/>
	2.6	140	$0,011 \times d_1$	200	$0,008 \times d_1$	<input type="checkbox"/>	<input type="checkbox"/>	<input type="checkbox"/>	<input checked="" type="checkbox"/>
	2.7	90	$0,008 \times d_1$	120	$0,006 \times d_1$			<input type="checkbox"/>	<input checked="" type="checkbox"/>
	2.8	90	$0,008 \times d_1$	120	$0,006 \times d_1$			<input type="checkbox"/>	<input checked="" type="checkbox"/>
	3.1								
	3.2								
4.1	290	$0,020 \times d_1$	400	$0,015 \times d_1$			<input type="checkbox"/>	<input checked="" type="checkbox"/>	
4.2	430	$0,020 \times d_1$	580	$0,015 \times d_1$			<input type="checkbox"/>	<input checked="" type="checkbox"/>	
4.3									
4.4									
5.1									
5.2	100	$0,008 \times d_1$	130	$0,006 \times d_1$			<input type="checkbox"/>	<input checked="" type="checkbox"/>	
5.3	180	$0,017 \times d_1$	270	$0,012 \times d_1$	<input type="checkbox"/>	<input checked="" type="checkbox"/>		<input checked="" type="checkbox"/>	
S	1.1	100	$0,010 \times d_1$	130	$0,007 \times d_1$			<input type="checkbox"/>	<input checked="" type="checkbox"/>
	1.2	80	$0,008 \times d_1$	110	$0,006 \times d_1$			<input type="checkbox"/>	<input checked="" type="checkbox"/>
	1.3	40	$0,007 \times d_1$	60	$0,005 \times d_1$			<input type="checkbox"/>	<input checked="" type="checkbox"/>
	2.1	70	$0,008 \times d_1$	100	$0,006 \times d_1$			<input type="checkbox"/>	<input checked="" type="checkbox"/>
	2.2	25	$0,006 \times d_1$	40	$0,004 \times d_1$			<input type="checkbox"/>	<input checked="" type="checkbox"/>
	2.3	25	$0,006 \times d_1$	30	$0,004 \times d_1$			<input type="checkbox"/>	<input checked="" type="checkbox"/>
	2.4	25	$0,006 \times d_1$	30	$0,004 \times d_1$			<input type="checkbox"/>	<input checked="" type="checkbox"/>
2.5	15	$0,006 \times d_1$	25	$0,004 \times d_1$			<input type="checkbox"/>	<input checked="" type="checkbox"/>	
2.6	25	$0,006 \times d_1$	30	$0,004 \times d_1$			<input type="checkbox"/>	<input checked="" type="checkbox"/>	
H	1.1								
	1.2								
	1.3								
	1.4								
	1.5								

v_c = Schnittgeschwindigkeit · Cutting speed
 f_z = Vorschub pro Zahn · Feed per tooth

■ = sehr gut geeignet · very suitable
□ = gut geeignet · suitable

- Multifunktionales Hochleistungswerkzeug
- 2 Schneiden zur Mitte
- 3 Baulängen verfügbar
- Mit extra langer Umfangsschneide (min. $4 \times d_1$)

- Multi-functional, high performance tool
- 2 centre cutting edges
- 3 lengths available
- with extra long peripheral cutting edge (min. $4 \times d_1$)

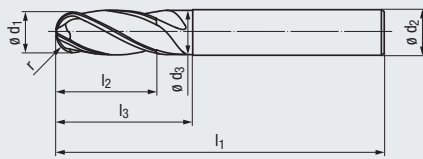

N

HM

DIN 6535
HA
HB

35-38° Kugel

3-5°

MMS
MQL

v_c/f_z
25



Allround

Beschichtung · Coating

TIALN

Einsatzgebiete – Material (siehe Seite 4)

- In fast allen Werkstoffen einsetzbar
- Zum HSC-Schlichten geeignet
- Auch zum Besäumen geeignet

Applications – material (see page 4)

- For almost all materials
- Suitable for HSC finishing
- Also suitable for trimming

P	1.1-5.1	
M	1.1-2.1	3.1-4.1
K	1.1-2.2	3.1-4.2
N	2.1-2.8, 4.1-4.2	
N	5.2-5.3	
S	1.1-2.6	

Extra lange Ausführung · Extra long design

Bestell-Code · Order code

2504A

ϕd_1 h10	r	l_2	l_3	l_1	ϕd_3	ϕd_2 h6	Z (Flutes)	Dimens.- Code	
6	3	40	60	100	5,8	6	4	.006	●
8	4	40	60	100	7,7	8	4	.008	●
10	5	40	55	100	9,5	10	4	.010	●
12	6	45	50	100	11,5	12	4	.012	●
16	8	65	90	150	15,5	16	4	.016	●



15-90° Alle Schneiden effektiv im Einsatz
All cutting edges in operation

0-15° 2 Schneiden effektiv im Einsatz
2 cutting edges in operation



Hartmetall-Kugelfräser – extra lange Ausführung
Solid carbide ball nose end mills – extra long design

N

Gültig für · Valid for
2504A

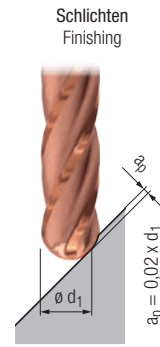
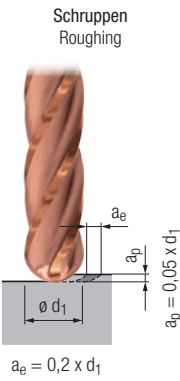

	V_c [m/min]	f_z [mm]	V_c [m/min]	f_z [mm]			MMS MQL		
P	1.1	140	0,014 x d ₁	190	0,010 x d ₁	<input type="checkbox"/>	<input checked="" type="checkbox"/>	<input type="checkbox"/>	<input checked="" type="checkbox"/>
	2.1	120	0,013 x d ₁	160	0,009 x d ₁	<input type="checkbox"/>	<input checked="" type="checkbox"/>	<input type="checkbox"/>	<input checked="" type="checkbox"/>
	3.1	100	0,011 x d ₁	140	0,008 x d ₁	<input type="checkbox"/>	<input checked="" type="checkbox"/>	<input type="checkbox"/>	<input type="checkbox"/>
	4.1	80	0,010 x d ₁	110	0,007 x d ₁	<input type="checkbox"/>	<input checked="" type="checkbox"/>	<input type="checkbox"/>	<input type="checkbox"/>
	5.1	70	0,008 x d ₁	90	0,006 x d ₁	<input type="checkbox"/>	<input checked="" type="checkbox"/>	<input type="checkbox"/>	<input type="checkbox"/>
M	1.1	70	0,008 x d ₁	90	0,006 x d ₁			<input type="checkbox"/>	<input checked="" type="checkbox"/>
	2.1	60	0,008 x d ₁	80	0,006 x d ₁			<input type="checkbox"/>	<input checked="" type="checkbox"/>
	3.1	50	0,006 x d ₁	60	0,005 x d ₁			<input type="checkbox"/>	<input checked="" type="checkbox"/>
	4.1	30	0,006 x d ₁	50	0,005 x d ₁			<input type="checkbox"/>	<input checked="" type="checkbox"/>
K	1.1	140	0,014 x d ₁	190	0,010 x d ₁	<input type="checkbox"/>	<input checked="" type="checkbox"/>		<input type="checkbox"/>
	1.2	140	0,014 x d ₁	190	0,010 x d ₁	<input type="checkbox"/>	<input checked="" type="checkbox"/>		<input type="checkbox"/>
	2.1	120	0,011 x d ₁	160	0,008 x d ₁	<input type="checkbox"/>	<input checked="" type="checkbox"/>		<input type="checkbox"/>
	2.2	120	0,011 x d ₁	160	0,008 x d ₁	<input type="checkbox"/>	<input checked="" type="checkbox"/>		<input type="checkbox"/>
	3.1	100	0,011 x d ₁	140	0,008 x d ₁	<input type="checkbox"/>	<input checked="" type="checkbox"/>		<input type="checkbox"/>
	3.2	100	0,011 x d ₁	140	0,008 x d ₁	<input type="checkbox"/>	<input checked="" type="checkbox"/>		<input type="checkbox"/>
	4.1	80	0,008 x d ₁	110	0,006 x d ₁	<input type="checkbox"/>	<input checked="" type="checkbox"/>		<input type="checkbox"/>
	4.2	70	0,008 x d ₁	90	0,006 x d ₁	<input type="checkbox"/>	<input checked="" type="checkbox"/>		<input type="checkbox"/>
N	1.1								
	1.2								
	1.3								
	1.4								
	1.5								
	1.6								
	2.1	120	0,014 x d ₁	160	0,010 x d ₁			<input type="checkbox"/>	<input checked="" type="checkbox"/>
	2.2	120	0,014 x d ₁	160	0,010 x d ₁			<input type="checkbox"/>	<input checked="" type="checkbox"/>
	2.3	120	0,014 x d ₁	160	0,010 x d ₁	<input type="checkbox"/>	<input type="checkbox"/>	<input type="checkbox"/>	<input checked="" type="checkbox"/>
	2.4	100	0,011 x d ₁	140	0,008 x d ₁			<input type="checkbox"/>	<input checked="" type="checkbox"/>
	2.5	100	0,011 x d ₁	140	0,008 x d ₁			<input type="checkbox"/>	<input checked="" type="checkbox"/>
	2.6	100	0,011 x d ₁	140	0,008 x d ₁	<input type="checkbox"/>	<input type="checkbox"/>	<input type="checkbox"/>	<input checked="" type="checkbox"/>
	2.7	70	0,008 x d ₁	90	0,006 x d ₁			<input type="checkbox"/>	<input checked="" type="checkbox"/>
	2.8	70	0,008 x d ₁	90	0,006 x d ₁			<input type="checkbox"/>	<input checked="" type="checkbox"/>
	3.1								
	3.2								
4.1	200	0,020 x d ₁	280	0,015 x d ₁			<input type="checkbox"/>	<input checked="" type="checkbox"/>	
4.2	300	0,020 x d ₁	400	0,015 x d ₁			<input type="checkbox"/>	<input checked="" type="checkbox"/>	
4.3									
4.4									
5.1									
5.2	70	0,008 x d ₁	130	0,006 x d ₁			<input type="checkbox"/>	<input checked="" type="checkbox"/>	
5.3	120	0,017 x d ₁	270	0,012 x d ₁	<input type="checkbox"/>	<input checked="" type="checkbox"/>		<input checked="" type="checkbox"/>	
S	1.1	70	0,010 x d ₁	90	0,007 x d ₁			<input type="checkbox"/>	<input checked="" type="checkbox"/>
	1.2	60	0,008 x d ₁	80	0,006 x d ₁			<input type="checkbox"/>	<input checked="" type="checkbox"/>
	1.3	30	0,007 x d ₁	40	0,005 x d ₁			<input type="checkbox"/>	<input checked="" type="checkbox"/>
	2.1	50	0,008 x d ₁	70	0,006 x d ₁			<input type="checkbox"/>	<input checked="" type="checkbox"/>
	2.2	20	0,006 x d ₁	25	0,004 x d ₁			<input type="checkbox"/>	<input checked="" type="checkbox"/>
	2.3	20	0,006 x d ₁	25	0,004 x d ₁			<input type="checkbox"/>	<input checked="" type="checkbox"/>
	2.4	20	0,006 x d ₁	25	0,004 x d ₁			<input type="checkbox"/>	<input checked="" type="checkbox"/>
	2.5	15	0,006 x d ₁	20	0,004 x d ₁			<input type="checkbox"/>	<input checked="" type="checkbox"/>
2.6	20	0,006 x d ₁	25	0,004 x d ₁			<input type="checkbox"/>	<input checked="" type="checkbox"/>	
H	1.1								
	1.2								
	1.3								
	1.4								
	1.5								

v_c = Schnittgeschwindigkeit · Cutting speed
 f_z = Vorschub pro Zahn · Feed per tooth

■ = sehr gut geeignet · very suitable
□ = gut geeignet · suitable

- Multifunktionales Hochleistungswerkzeug
- Patentierte Querschnitte
- Mit 220-240° Kugelschneide

- Multi-functional, high performance tool
- Patented chisel edge
- With 220-240° ball nose

N

HM

DIN 6535
HA
HB

15°

220-240°

MMS
MQL

≤ 55
HRC

V_c/f_z
19



Allround

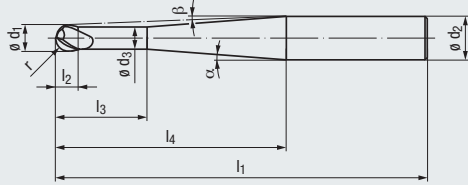

Beschichtung · Coating

TIALN

Einsatzgebiete – Material (siehe Seite 4)

- In vielen Werkstoffen einsetzbar
- Zum Schruppen und Schlichten geeignet
- Hinterschnittige Bearbeitung möglich

Applications – material (see page 4)

- For many materials
- Suitable for roughing and finishing
- Machining of undercuts

P	1.1-5.1
K	1.1-4.2
N	2.1-2.8 1.2-1.4, 5.2
H	1.1-1.2

Extra lange Ausführung · Extra long design

Bestell-Code · Order code

1935A

$\varnothing d_1$ $\pm 0,01$	r $\pm 0,005$	l_2	l_3	l_1	$\varnothing d_3$	l_4	$\varnothing d_2$ h5	α	β	Z (Flutes)	Dimens.- Code
2	1	1,3	17	80	1,8	40	6	6°	3°	2	.002
3	1,5	2	17	80	2,7	40	6	4,5°	2,5°	2	.003
4	2	2,8	18	80	3,2	40	6	4°	1,5°	2	.004
6	3	4,3	20	80	5	40	6	2°	–	2	.006
8	4	5,7	26	100	6,8	60	8	1,5°	–	2	.008
10	5	7	28	120	8	75	10	1,5°	–	2	.010
12	6	9	30	120	8	75	12	3°	–	2	.012
12	6	9	40	160	8	110	12	2°	–	2	.012160

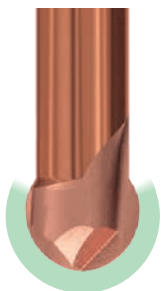

Kugel auf bis zu 240° schneidend einsetzbar
Ball nose with fully functional cutting edge up to 240°



Hartmetall-Kugelfräser „Lollipop“ – extra lange Ausführung
Solid carbide ball nose end mills “Lollipop” – extra long design

N

Gültig für · Valid for
1935A

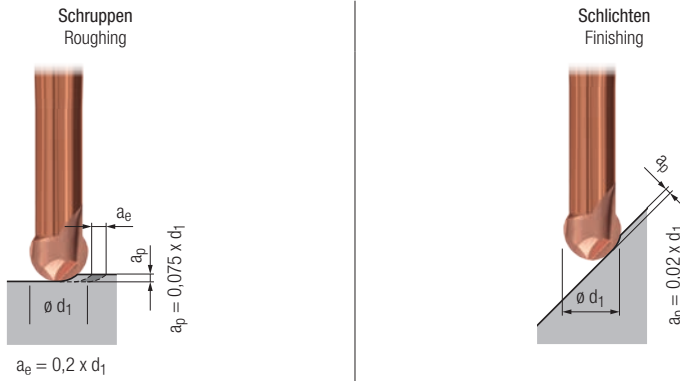

	V_c [m/min]	f_z [mm]	V_c [m/min]	f_z [mm]			MMS MQL	
P	1.1	220	$0,014 \times d_1$	300	$0,010 \times d_1$	<input type="checkbox"/>	<input checked="" type="checkbox"/>	<input type="checkbox"/>
	2.1	190	$0,013 \times d_1$	260	$0,009 \times d_1$	<input type="checkbox"/>	<input checked="" type="checkbox"/>	<input type="checkbox"/>
	3.1	160	$0,011 \times d_1$	220	$0,008 \times d_1$	<input type="checkbox"/>	<input checked="" type="checkbox"/>	<input type="checkbox"/>
	4.1	130	$0,010 \times d_1$	180	$0,007 \times d_1$	<input type="checkbox"/>	<input checked="" type="checkbox"/>	<input type="checkbox"/>
	5.1	110	$0,008 \times d_1$	150	$0,006 \times d_1$	<input type="checkbox"/>	<input checked="" type="checkbox"/>	<input type="checkbox"/>
M	1.1	110	$0,008 \times d_1$	150	$0,006 \times d_1$			<input type="checkbox"/>
	2.1	90	$0,008 \times d_1$	120	$0,006 \times d_1$			<input type="checkbox"/>
	3.1	70	$0,006 \times d_1$	90	$0,005 \times d_1$			<input type="checkbox"/>
	4.1	50	$0,006 \times d_1$	70	$0,005 \times d_1$			<input type="checkbox"/>
K	1.1	220	$0,014 \times d_1$	300	$0,010 \times d_1$	<input type="checkbox"/>	<input checked="" type="checkbox"/>	<input type="checkbox"/>
	1.2	220	$0,014 \times d_1$	300	$0,010 \times d_1$	<input type="checkbox"/>	<input checked="" type="checkbox"/>	<input type="checkbox"/>
	2.1	200	$0,011 \times d_1$	260	$0,008 \times d_1$	<input type="checkbox"/>	<input checked="" type="checkbox"/>	<input type="checkbox"/>
	2.2	200	$0,011 \times d_1$	260	$0,008 \times d_1$	<input type="checkbox"/>	<input checked="" type="checkbox"/>	<input type="checkbox"/>
	3.1	160	$0,011 \times d_1$	220	$0,008 \times d_1$	<input type="checkbox"/>	<input checked="" type="checkbox"/>	<input type="checkbox"/>
	3.2	160	$0,011 \times d_1$	220	$0,008 \times d_1$	<input type="checkbox"/>	<input checked="" type="checkbox"/>	<input type="checkbox"/>
	4.1	130	$0,008 \times d_1$	180	$0,006 \times d_1$	<input type="checkbox"/>	<input checked="" type="checkbox"/>	<input type="checkbox"/>
	4.2	110	$0,008 \times d_1$	150	$0,006 \times d_1$	<input type="checkbox"/>	<input checked="" type="checkbox"/>	<input type="checkbox"/>
N	1.1							
	1.2	900	$0,020 \times d_1$	1200	$0,014 \times d_1$			<input type="checkbox"/>
	1.3	900	$0,017 \times d_1$	1200	$0,012 \times d_1$			<input type="checkbox"/>
	1.4	600	$0,020 \times d_1$	800	$0,014 \times d_1$			<input type="checkbox"/>
	1.5							
	1.6							
	2.1	200	$0,014 \times d_1$	260	$0,010 \times d_1$			<input type="checkbox"/>
	2.2	200	$0,014 \times d_1$	260	$0,010 \times d_1$			<input type="checkbox"/>
	2.3	200	$0,014 \times d_1$	260	$0,010 \times d_1$	<input type="checkbox"/>	<input type="checkbox"/>	<input type="checkbox"/>
	2.4	160	$0,011 \times d_1$	220	$0,008 \times d_1$			<input type="checkbox"/>
	2.5	160	$0,011 \times d_1$	220	$0,008 \times d_1$			<input type="checkbox"/>
	2.6	160	$0,011 \times d_1$	220	$0,008 \times d_1$	<input type="checkbox"/>	<input type="checkbox"/>	<input type="checkbox"/>
	2.7	100	$0,008 \times d_1$	130	$0,006 \times d_1$			<input type="checkbox"/>
	2.8	100	$0,008 \times d_1$	130	$0,006 \times d_1$			<input type="checkbox"/>
	3.1							
	3.2							
4.1								
4.2								
4.3								
4.4								
5.1								
5.2	110	$0,008 \times d_1$	150	$0,006 \times d_1$			<input type="checkbox"/>	
5.3								
S	1.1	110	$0,010 \times d_1$	150	$0,007 \times d_1$			<input type="checkbox"/>
	1.2	90	$0,008 \times d_1$	120	$0,006 \times d_1$			<input type="checkbox"/>
	1.3	50	$0,007 \times d_1$	70	$0,005 \times d_1$			<input type="checkbox"/>
	2.1	80	$0,008 \times d_1$	110	$0,006 \times d_1$			<input type="checkbox"/>
	2.2	30	$0,006 \times d_1$	50	$0,004 \times d_1$			<input type="checkbox"/>
	2.3	30	$0,006 \times d_1$	40	$0,004 \times d_1$			<input type="checkbox"/>
	2.4	30	$0,006 \times d_1$	40	$0,004 \times d_1$			<input type="checkbox"/>
2.5	20	$0,006 \times d_1$	30	$0,004 \times d_1$			<input type="checkbox"/>	
2.6	30	$0,006 \times d_1$	40	$0,004 \times d_1$			<input type="checkbox"/>	
H	1.1			150	$0,006 \times d_1$	<input type="checkbox"/>	<input checked="" type="checkbox"/>	
	1.2			130	$0,005 \times d_1$	<input type="checkbox"/>	<input checked="" type="checkbox"/>	
	1.3							
	1.4							
	1.5							

v_c = Schnittgeschwindigkeit · Cutting speed
 f_z = Vorschub pro Zahn · Feed per tooth

■ = sehr gut geeignet · very suitable
□ = gut geeignet · suitable

- Multifunktionales Hochleistungswerkzeug
- Hochgenauer Eckenradius
- 2 Baulängen verfügbar

- Multi-functional, high performance tool
- High-precision corner radius
- 2 lengths available

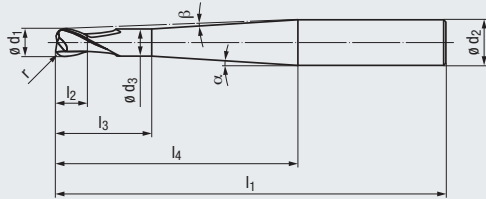
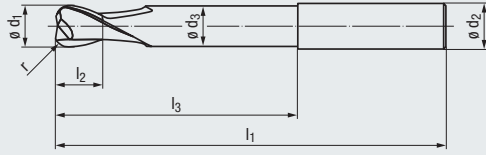

N

HM

DIN 6535
HA
HB

30° **Torus**

MMS
MQL

≤ 55 HRC

V_c/f_z
29



Allround

Beschichtung · Coating

TIALN

Einsatzgebiete – Material (siehe Seite 4)

Applications – material (see page 4)

- In fast allen Werkstoffen einsetzbar
- Zum Schruppen, Schlichten sowie zum HSC-Schlichten geeignet

- For almost all materials
- Suitable for roughing, finishing and HSC finishing

P 1.1-5.1

M 1.1-4.1

K 1.1-4.2

N 2.1-2.8, 5.2 1.2-1.4

S 2.1-2.3 2.4-2.6

H 1.1-1.2

Kurze Ausführung · Short design

Bestell-Code · Order code

2552A

$\varnothing d_1$ ±0,01	r ±0,005	l_2	l_3	l_1	$\varnothing d_3$	l_4	$\varnothing d_2$ h5	α	β	Z (Flutes)	Dimens.- Code		
0,5	0,1	1	2	57	0,45	20	6	10°	8,5°	2	.0005	●	
1	0,2	2	4	57	0,95	20	6	10°	8°	2	.101	●	
1	0,25	2	4	57	0,95	20	6	10°	8°	2	.001	●	
1,5	0,2	2,5	7,5	57	1,4	20	6	12,5°	7°	2	.1015	●	
1,5	0,3	2,5	7,5	57	1,4	20	6	12,5°	7°	2	.0015	●	
2	0,2	3	8	57	1,8	20	6	12°	6,5°	2	.102	●	
2	0,5	3	8	57	1,8	20	6	12°	6,5°	2	.002	●	
3	0,2	3,5	10	57	2,8	20	6	11,5°	5°	2	.103	●	
3	0,5	3,5	10	57	2,8	20	6	11,5°	5°	2	.003	●	
4	0,3	4	12	57	3,8	20	6	11°	3,5°	2	.204	●	
4	0,5	4	12	57	3,8	20	6	11°	3,5°	2	.104	●	
4	1	4	12	57	3,8	20	6	11°	3,5°	2	.004	●	
5	0,3	5	14	57	4,7	20	6	10°	2°	2	.305	●	
5	0,5	5	14	57	4,7	20	6	10°	2°	2	.205	●	
5	1	5	14	57	4,7	20	6	10°	2°	2	.105	●	
5	1,5	5	14	57	4,7	20	6	10°	2°	2	.005	●	
6	0,3	6	20	57	5,6	–	6	–	–	2	.306	●	
6	0,5	6	20	57	5,6	–	6	–	–	2	.206	●	
6	1	6	20	57	5,6	–	6	–	–	2	.106	●	
6	2	6	20	57	5,6	–	6	–	–	2	.006	●	
8	0,3	7	25	63	7,6	–	8	–	–	2	.408	●	
8	0,5	7	25	63	7,6	–	8	–	–	2	.308	●	
8	1	7	25	63	7,6	–	8	–	–	2	.208	●	
8	2	7	25	63	7,6	–	8	–	–	2	.008	●	
10	0,5	8	30	72	9,6	–	10	–	–	2	.710	●	
10	1	8	30	72	9,6	–	10	–	–	2	.610	●	
10	1,5	8	30	72	9,6	–	10	–	–	2	.210	●	
10	2	8	30	72	9,6	–	10	–	–	2	.410	●	
10	3	8	30	72	9,6	–	10	–	–	2	.010	●	
12	0,5	10	35	83	11,5	–	12	–	–	2	.612	●	
12	1	10	35	83	11,5	–	12	–	–	2	.512	●	
12	1,5	10	35	83	11,5	–	12	–	–	2	.112	●	
12	2	10	35	83	11,5	–	12	–	–	2	.312	●	
12	4	10	35	83	11,5	–	12	–	–	2	.012	●	



Hartmetall-Torusfräser – kurze Ausführung
Solid carbide torus end mills – short design

N

Gültig für · Valid for
2552A

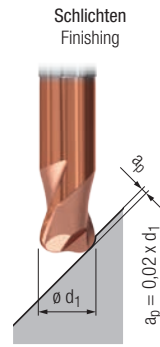
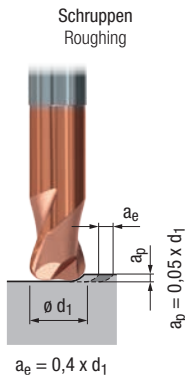

	V_c [m/min]	f_z [mm]	V_c [m/min]	f_z [mm]			MMS MQL		
P	1.1	220	$0,014 \times d_1$	300	$0,010 \times d_1$	<input type="checkbox"/>	<input checked="" type="checkbox"/>	<input type="checkbox"/>	<input checked="" type="checkbox"/>
	2.1	190	$0,013 \times d_1$	260	$0,009 \times d_1$	<input type="checkbox"/>	<input checked="" type="checkbox"/>	<input type="checkbox"/>	<input checked="" type="checkbox"/>
	3.1	160	$0,011 \times d_1$	220	$0,008 \times d_1$	<input type="checkbox"/>	<input checked="" type="checkbox"/>	<input type="checkbox"/>	<input type="checkbox"/>
	4.1	130	$0,010 \times d_1$	180	$0,007 \times d_1$	<input type="checkbox"/>	<input checked="" type="checkbox"/>	<input type="checkbox"/>	<input type="checkbox"/>
	5.1	110	$0,008 \times d_1$	150	$0,006 \times d_1$	<input type="checkbox"/>	<input checked="" type="checkbox"/>	<input type="checkbox"/>	<input type="checkbox"/>
M	1.1	110	$0,008 \times d_1$	150	$0,006 \times d_1$			<input type="checkbox"/>	<input checked="" type="checkbox"/>
	2.1	90	$0,008 \times d_1$	120	$0,006 \times d_1$			<input type="checkbox"/>	<input checked="" type="checkbox"/>
	3.1	70	$0,006 \times d_1$	90	$0,005 \times d_1$			<input type="checkbox"/>	<input checked="" type="checkbox"/>
	4.1	50	$0,006 \times d_1$	70	$0,005 \times d_1$			<input type="checkbox"/>	<input checked="" type="checkbox"/>
K	1.1	220	$0,014 \times d_1$	300	$0,010 \times d_1$	<input type="checkbox"/>	<input checked="" type="checkbox"/>		<input type="checkbox"/>
	1.2	220	$0,014 \times d_1$	300	$0,010 \times d_1$	<input type="checkbox"/>	<input checked="" type="checkbox"/>		<input type="checkbox"/>
	2.1	200	$0,011 \times d_1$	260	$0,008 \times d_1$	<input type="checkbox"/>	<input checked="" type="checkbox"/>		<input type="checkbox"/>
	2.2	200	$0,011 \times d_1$	260	$0,008 \times d_1$	<input type="checkbox"/>	<input checked="" type="checkbox"/>		<input type="checkbox"/>
	3.1	160	$0,011 \times d_1$	220	$0,008 \times d_1$	<input type="checkbox"/>	<input checked="" type="checkbox"/>		<input type="checkbox"/>
	3.2	160	$0,011 \times d_1$	220	$0,008 \times d_1$	<input type="checkbox"/>	<input checked="" type="checkbox"/>		<input type="checkbox"/>
	4.1	130	$0,008 \times d_1$	180	$0,006 \times d_1$	<input type="checkbox"/>	<input checked="" type="checkbox"/>		<input type="checkbox"/>
	4.2	110	$0,008 \times d_1$	150	$0,006 \times d_1$	<input type="checkbox"/>	<input checked="" type="checkbox"/>		<input type="checkbox"/>
N	1.1								
	1.2	1000	$0,020 \times d_1$	1350	$0,014 \times d_1$			<input type="checkbox"/>	<input checked="" type="checkbox"/>
	1.3	1000	$0,017 \times d_1$	1350	$0,012 \times d_1$			<input type="checkbox"/>	<input checked="" type="checkbox"/>
	1.4	600	$0,020 \times d_1$	800	$0,014 \times d_1$			<input type="checkbox"/>	<input checked="" type="checkbox"/>
	1.5								
	1.6								
	2.1	200	$0,014 \times d_1$	260	$0,010 \times d_1$			<input type="checkbox"/>	<input checked="" type="checkbox"/>
	2.2	200	$0,014 \times d_1$	260	$0,010 \times d_1$			<input type="checkbox"/>	<input checked="" type="checkbox"/>
	2.3	200	$0,014 \times d_1$	260	$0,010 \times d_1$	<input type="checkbox"/>	<input type="checkbox"/>	<input type="checkbox"/>	<input checked="" type="checkbox"/>
	2.4	160	$0,011 \times d_1$	220	$0,008 \times d_1$			<input type="checkbox"/>	<input checked="" type="checkbox"/>
	2.5	160	$0,011 \times d_1$	220	$0,008 \times d_1$			<input type="checkbox"/>	<input checked="" type="checkbox"/>
	2.6	160	$0,011 \times d_1$	220	$0,008 \times d_1$	<input type="checkbox"/>	<input type="checkbox"/>	<input type="checkbox"/>	<input checked="" type="checkbox"/>
	2.7	100	$0,008 \times d_1$	130	$0,006 \times d_1$			<input type="checkbox"/>	<input checked="" type="checkbox"/>
	2.8	100	$0,008 \times d_1$	130	$0,006 \times d_1$			<input type="checkbox"/>	<input checked="" type="checkbox"/>
	3.1								
	3.2								
4.1									
4.2									
4.3									
4.4									
5.1									
5.2	110	$0,008 \times d_1$	150	$0,006 \times d_1$			<input type="checkbox"/>	<input checked="" type="checkbox"/>	
5.3									
S	1.1								
	1.2								
	1.3								
	2.1	80	$0,008 \times d_1$	110	$0,006 \times d_1$			<input type="checkbox"/>	<input checked="" type="checkbox"/>
	2.2	30	$0,006 \times d_1$	50	$0,004 \times d_1$			<input type="checkbox"/>	<input checked="" type="checkbox"/>
	2.3	30	$0,006 \times d_1$	40	$0,004 \times d_1$			<input type="checkbox"/>	<input checked="" type="checkbox"/>
	2.4	30	$0,006 \times d_1$	40	$0,004 \times d_1$			<input type="checkbox"/>	<input checked="" type="checkbox"/>
2.5	20	$0,006 \times d_1$	30	$0,004 \times d_1$			<input type="checkbox"/>	<input checked="" type="checkbox"/>	
2.6	30	$0,006 \times d_1$	40	$0,004 \times d_1$			<input type="checkbox"/>	<input checked="" type="checkbox"/>	
H	1.1			150	$0,006 \times d_1$	<input type="checkbox"/>	<input checked="" type="checkbox"/>		
	1.2			130	$0,005 \times d_1$	<input type="checkbox"/>	<input checked="" type="checkbox"/>		
	1.3								
	1.4								
	1.5								

v_c = Schnittgeschwindigkeit · Cutting speed
 f_z = Vorschub pro Zahn · Feed per tooth

■ = sehr gut geeignet · very suitable
□ = gut geeignet · suitable

- Multifunktionales Hochleistungswerkzeug
- Hochgenauer Eckenradius
- 2 Baulängen verfügbar

- Multi-functional, high performance tool
- High-precision corner radius
- 2 lengths available

N

HM

DIN 6535

Torus



Allround

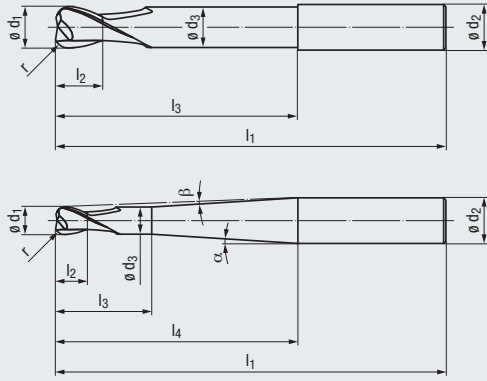

Beschichtung · Coating

TIALN

Einsatzgebiete – Material (siehe Seite 4)

Applications – material (see page 4)

- In fast allen Werkstoffen einsetzbar
- Zum Schruppen, Schlichten sowie zum HSC-Schlichten geeignet

- For almost all materials
- Suitable for roughing, finishing and HSC finishing

P	1.1-5.1
M	1.1-4.1
K	1.1-4.2
N	2.1-2.8, 5.2 1.2-1.4
S	2.1-2.3 2.4-2.6
H	1.1-1.2

Extra lange Ausführung · Extra long design

Bestell-Code · Order code

2553A

$\varnothing d_1$ $\pm 0,01$	r $\pm 0,005$	l_2	l_3	l_1	$\varnothing d_3$	l_4	$\varnothing d_2$ h5	α	β	Z (Flutes)	Dimens.- Code		
1	0,2	2	4	80	0,95	40	6	4,5°	4°	2	.101	●	
1	0,25	2	4	80	0,95	40	6	4,5°	4°	2	.001	●	
1,5	0,2	2,5	7,5	80	1,4	40	6	4,5°	3,5°	2	.1015	●	
1,5	0,3	2,5	7,5	80	1,4	40	6	4,5°	3,5°	2	.0015	●	
2	0,2	3	8	80	1,8	40	6	4°	3°	2	.102	●	
2	0,5	3	8	80	1,8	40	6	4°	3°	2	.002	●	
3	0,2	3,5	12	80	2,8	40	6	3,5°	2,5°	2	.103	●	
3	0,5	3,5	12	80	2,8	40	6	3,5°	2,5°	2	.003	●	
4	0,3	4	20	80	3,8	40	6	4°	1,5°	2	.204	●	
4	0,5	4	20	80	3,8	40	6	4°	1,5°	2	.104	●	
4	1	4	20	80	3,8	40	6	4°	1,5°	2	.004	●	
5	0,3	5	25	80	4,7	40	6	3°	1°	2	.305	●	
5	0,5	5	25	80	4,7	40	6	3°	1°	2	.205	●	
5	1	5	25	80	4,7	40	6	3°	1°	2	.105	●	
5	1,5	5	25	80	4,7	40	6	3°	1°	2	.005	●	
6	0,3	6	40	80	5,6	-	6	-	-	2	.306	●	
6	0,5	6	40	80	5,6	-	6	-	-	2	.206	●	
6	1	6	40	80	5,6	-	6	-	-	2	.106	●	
6	2	6	40	80	5,6	-	6	-	-	2	.006	●	
8	0,3	7	60	100	7,6	-	8	-	-	2	.408	●	
8	0,5	7	60	100	7,6	-	8	-	-	2	.308	●	
8	1	7	60	100	7,6	-	8	-	-	2	.208	●	
8	2	7	60	100	7,6	-	8	-	-	2	.008	●	
8	2,5	7	60	100	7,6	-	8	-	-	2	.108	●	
10	0,5	8	50	100	9,6	-	10	-	-	2	.710	●	
10	1	8	50	100	9,6	-	10	-	-	2	.610	●	
10	1,5	8	50	100	9,6	-	10	-	-	2	.510	●	
10	1,5	8	75	120	9,6	-	10	-	-	2	.210	●	
10	2	8	50	100	9,6	-	10	-	-	2	.410	●	
10	2,5	8	75	120	9,6	-	10	-	-	2	.110	●	
10	3	8	50	100	9,6	-	10	-	-	2	.310	●	
10	3	8	75	120	9,6	-	10	-	-	2	.010	●	
12	0,5	10	70	120	11,5	-	12	-	-	2	.612	●	
12	1	10	70	120	11,5	-	12	-	-	2	.512	●	
12	1,5	10	70	120	11,5	-	12	-	-	2	.412	●	
12	1,5	10	70	160	11,5	-	12	-	-	2	.112	●	
12	2	10	70	120	11,5	-	12	-	-	2	.312	●	
12	4	8	70	120	11,5	-	12	-	-	2	.212	●	
12	4	10	70	160	11,5	-	12	-	-	2	.012	●	

● = Lagerwerkzeug · Stock tool

Bestell-Beispiel · Ordering example: **2553A.101**



Hartmetall-Torusfräser – extra lang Ausführung
Solid carbide torus end mills – extra long design

N

Gültig für · Valid for
2553A

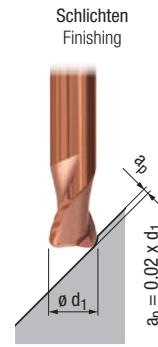
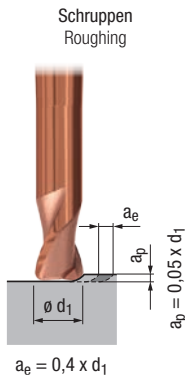

	V_c [m/min]	f_z [mm]	V_c [m/min]	f_z [mm]			MMS MQL	
P	1.1	220	$0,014 \times d_1$	300	$0,010 \times d_1$	<input type="checkbox"/>	<input checked="" type="checkbox"/>	<input type="checkbox"/>
	2.1	190	$0,013 \times d_1$	260	$0,009 \times d_1$	<input type="checkbox"/>	<input checked="" type="checkbox"/>	<input type="checkbox"/>
	3.1	160	$0,011 \times d_1$	220	$0,008 \times d_1$	<input type="checkbox"/>	<input checked="" type="checkbox"/>	<input type="checkbox"/>
	4.1	130	$0,010 \times d_1$	180	$0,007 \times d_1$	<input type="checkbox"/>	<input checked="" type="checkbox"/>	<input type="checkbox"/>
	5.1	110	$0,008 \times d_1$	150	$0,006 \times d_1$	<input type="checkbox"/>	<input checked="" type="checkbox"/>	<input type="checkbox"/>
M	1.1	110	$0,008 \times d_1$	150	$0,006 \times d_1$			<input type="checkbox"/>
	2.1	90	$0,008 \times d_1$	120	$0,006 \times d_1$			<input type="checkbox"/>
	3.1	70	$0,006 \times d_1$	90	$0,005 \times d_1$			<input type="checkbox"/>
	4.1	50	$0,006 \times d_1$	70	$0,005 \times d_1$			<input type="checkbox"/>
K	1.1	220	$0,014 \times d_1$	300	$0,010 \times d_1$	<input type="checkbox"/>	<input checked="" type="checkbox"/>	<input type="checkbox"/>
	1.2	220	$0,014 \times d_1$	300	$0,010 \times d_1$	<input type="checkbox"/>	<input checked="" type="checkbox"/>	<input type="checkbox"/>
	2.1	200	$0,011 \times d_1$	260	$0,008 \times d_1$	<input type="checkbox"/>	<input checked="" type="checkbox"/>	<input type="checkbox"/>
	2.2	200	$0,011 \times d_1$	260	$0,008 \times d_1$	<input type="checkbox"/>	<input checked="" type="checkbox"/>	<input type="checkbox"/>
	3.1	160	$0,011 \times d_1$	220	$0,008 \times d_1$	<input type="checkbox"/>	<input checked="" type="checkbox"/>	<input type="checkbox"/>
	3.2	160	$0,011 \times d_1$	220	$0,008 \times d_1$	<input type="checkbox"/>	<input checked="" type="checkbox"/>	<input type="checkbox"/>
	4.1	130	$0,008 \times d_1$	180	$0,006 \times d_1$	<input type="checkbox"/>	<input checked="" type="checkbox"/>	<input type="checkbox"/>
	4.2	110	$0,008 \times d_1$	150	$0,006 \times d_1$	<input type="checkbox"/>	<input checked="" type="checkbox"/>	<input type="checkbox"/>
N	1.1							
	1.2	1000	$0,020 \times d_1$	1350	$0,014 \times d_1$			<input type="checkbox"/>
	1.3	1000	$0,017 \times d_1$	1350	$0,012 \times d_1$			<input type="checkbox"/>
	1.4	600	$0,020 \times d_1$	800	$0,014 \times d_1$			<input type="checkbox"/>
	1.5							
	1.6							
	2.1	200	$0,014 \times d_1$	260	$0,010 \times d_1$			<input type="checkbox"/>
	2.2	200	$0,014 \times d_1$	260	$0,010 \times d_1$			<input type="checkbox"/>
	2.3	200	$0,014 \times d_1$	260	$0,010 \times d_1$	<input type="checkbox"/>	<input type="checkbox"/>	<input type="checkbox"/>
	2.4	160	$0,011 \times d_1$	220	$0,008 \times d_1$			<input type="checkbox"/>
	2.5	160	$0,011 \times d_1$	220	$0,008 \times d_1$			<input type="checkbox"/>
	2.6	160	$0,011 \times d_1$	220	$0,008 \times d_1$	<input type="checkbox"/>	<input type="checkbox"/>	<input type="checkbox"/>
	2.7	100	$0,008 \times d_1$	130	$0,006 \times d_1$			<input type="checkbox"/>
	2.8	100	$0,008 \times d_1$	130	$0,006 \times d_1$			<input type="checkbox"/>
	3.1							
	3.2							
4.1								
4.2								
4.3								
4.4								
5.1								
5.2	110	$0,008 \times d_1$	150	$0,006 \times d_1$			<input type="checkbox"/>	
5.3								
S	1.1							
	1.2							
	1.3							
	2.1	80	$0,008 \times d_1$	110	$0,006 \times d_1$			<input type="checkbox"/>
	2.2	30	$0,006 \times d_1$	50	$0,004 \times d_1$			<input type="checkbox"/>
	2.3	30	$0,006 \times d_1$	40	$0,004 \times d_1$			<input type="checkbox"/>
	2.4	30	$0,006 \times d_1$	40	$0,004 \times d_1$			<input type="checkbox"/>
2.5	20	$0,006 \times d_1$	30	$0,004 \times d_1$			<input type="checkbox"/>	
2.6	30	$0,006 \times d_1$	40	$0,004 \times d_1$			<input type="checkbox"/>	
H	1.1			150	$0,006 \times d_1$	<input type="checkbox"/>	<input checked="" type="checkbox"/>	
	1.2			130	$0,005 \times d_1$	<input type="checkbox"/>	<input checked="" type="checkbox"/>	
	1.3							
	1.4							
	1.5							

v_c = Schnittgeschwindigkeit · Cutting speed
 f_z = Vorschub pro Zahn · Feed per tooth

■ = sehr gut geeignet · very suitable
□ = gut geeignet · suitable

- Multifunktionales Hochleistungswerkzeug
- Hochgenauer Eckenradius
- 3 Baulängen verfügbar

- Multi-functional, high performance tool
- High-precision corner radius
- 3 lengths available

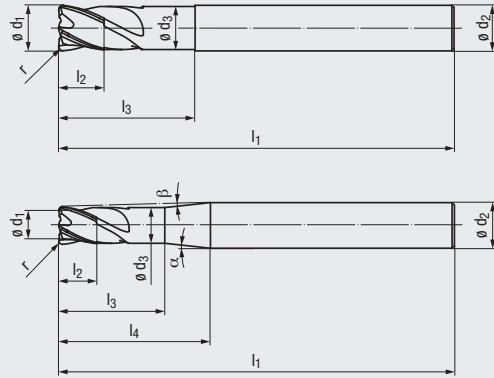

N

HM

DIN 6535
HA
HB

30°

Torus

1-2°

MMS
MQL

≤ 55
HRC

v_c/f_z
33



new



Allround

Beschichtung · Coating

TIALN

Einsatzgebiete – Material (siehe Seite 4)

Applications – material (see page 4)

- In schwer zerspanbaren Materialien einsetzbar
- Zum Schruppen, Schlichten sowie zum HSC-Schlichten geeignet

- For difficult to cut materials
- Suitable for roughing, finishing and HSC finishing

P	1.1-5.1
M	1.1-4.1
K	1.1-4.2
N	2.2-2.8, 5.2 2.1
S	1.1-2.6
H	1.1-1.2

$l_3 = 3 \times d_1$ – Kurze Ausführung · Short design

Bestell-Code · Order code											3835A		
$\varnothing d_1$	r	l_2	l_3	l_1	$\varnothing d_3$	l_4	$\varnothing d_2$	α	β	Z (Flutes)	Dimens.- Code		
-0,02	$\pm 0,005$						h5						
2	0,1	3	8	57	1,8	19,9	6	10°	6,5°	4	.002001	●	
2	0,2	3	8	57	1,8	19,9	6	10°	6,5°	4	.002002	●	
2	0,5	3	8	57	1,8	19,9	6	10°	6,5°	4	.002005	●	
3	0,2	3,5	10	57	2,8	19	6	10°	5,5°	4	.003002	●	
3	0,5	3,5	10	57	2,8	19	6	10°	5,5°	4	.003005	●	
4	0,3	4	12	57	3,8	18,2	6	10°	3,5°	4	.004003	●	
4	0,5	4	12	57	3,8	18,2	6	10°	3,5°	4	.004005	●	
4	1	4	12	57	3,8	18,2	6	10°	3,5°	4	.004010	●	
5	0,3	5	15	57	4,7	18,6	6	10°	2°	4	.005003	●	
5	0,5	5	15	57	4,7	18,6	6	10°	2°	4	.005005	●	
5	1	5	15	57	4,7	18,6	6	10°	2°	4	.005010	●	
6	0,3	6	20	57	5,6	—	6	—	—	4	.006003	●	
6	0,5	6	20	57	5,6	—	6	—	—	4	.006005	●	
6	1	6	20	57	5,6	—	6	—	—	4	.006010	●	
6	1,5	6	20	57	5,6	—	6	—	—	4	.006015	●	
6	2	6	20	57	5,6	—	6	—	—	4	.006020	●	
8	0,3	7	25	63	7,6	—	8	—	—	4	.008003	●	
8	0,5	7	25	63	7,6	—	8	—	—	4	.008005	●	
8	1	7	25	63	7,6	—	8	—	—	4	.008010	●	
8	2	7	25	63	7,6	—	8	—	—	4	.008020	●	
10	0,5	8	30	72	9,6	—	10	—	—	4	.010005	●	
10	1	8	30	72	9,6	—	10	—	—	4	.010010	●	
10	1,5	8	30	72	9,6	—	10	—	—	4	.010015	●	
10	2	8	30	72	9,6	—	10	—	—	4	.010020	●	
10	2,5	8	30	72	9,6	—	10	—	—	4	.010025	●	
10	3	8	30	72	9,6	—	10	—	—	4	.010030	●	
12	0,5	10	36	83	11,5	—	12	—	—	4	.012005	●	
12	1	10	36	83	11,5	—	12	—	—	4	.012010	●	
12	1,5	10	36	83	11,5	—	12	—	—	4	.012015	●	
12	2	10	36	83	11,5	—	12	—	—	4	.012020	●	
12	3	10	36	83	11,5	—	12	—	—	4	.012030	●	
12	4	10	36	83	11,5	—	12	—	—	4	.012040	●	



Hartmetall-Torusfräser – kurze Ausführung
Solid carbide torus end mills – short design

N

$l_3 = 3 \times d_1$

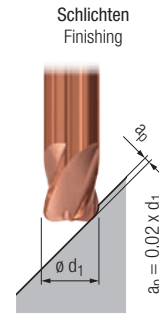
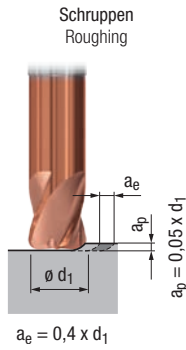

Gültig für · Valid for
3835A

	V_c [m/min]	f_z [mm]	V_c [m/min]	f_z [mm]				
P	1.1	250	$0,013 \times d_1$	300	$0,010 \times d_1$	<input type="checkbox"/>	<input checked="" type="checkbox"/>	<input type="checkbox"/>
	2.1	230	$0,012 \times d_1$	260	$0,009 \times d_1$	<input type="checkbox"/>	<input checked="" type="checkbox"/>	<input type="checkbox"/>
	3.1	200	$0,010 \times d_1$	230	$0,008 \times d_1$	<input type="checkbox"/>	<input checked="" type="checkbox"/>	<input type="checkbox"/>
	4.1	170	$0,009 \times d_1$	200	$0,007 \times d_1$	<input type="checkbox"/>	<input checked="" type="checkbox"/>	<input type="checkbox"/>
	5.1	150	$0,008 \times d_1$	180	$0,006 \times d_1$	<input type="checkbox"/>	<input checked="" type="checkbox"/>	<input type="checkbox"/>
M	1.1	140	$0,008 \times d_1$	180	$0,006 \times d_1$			<input type="checkbox"/>
	2.1	120	$0,008 \times d_1$	160	$0,006 \times d_1$			<input type="checkbox"/>
	3.1	100	$0,006 \times d_1$	120	$0,005 \times d_1$			<input type="checkbox"/>
	4.1	80	$0,006 \times d_1$	100	$0,005 \times d_1$			<input type="checkbox"/>
K	1.1	250	$0,014 \times d_1$	280	$0,010 \times d_1$	<input type="checkbox"/>	<input checked="" type="checkbox"/>	<input type="checkbox"/>
	1.2	250	$0,014 \times d_1$	280	$0,010 \times d_1$	<input type="checkbox"/>	<input checked="" type="checkbox"/>	<input type="checkbox"/>
	2.1	230	$0,011 \times d_1$	260	$0,008 \times d_1$	<input type="checkbox"/>	<input checked="" type="checkbox"/>	<input type="checkbox"/>
	2.2	230	$0,011 \times d_1$	260	$0,008 \times d_1$	<input type="checkbox"/>	<input checked="" type="checkbox"/>	<input type="checkbox"/>
	3.1	190	$0,011 \times d_1$	210	$0,008 \times d_1$	<input type="checkbox"/>	<input checked="" type="checkbox"/>	<input type="checkbox"/>
	3.2	190	$0,011 \times d_1$	210	$0,008 \times d_1$	<input type="checkbox"/>	<input checked="" type="checkbox"/>	<input type="checkbox"/>
	4.1	160	$0,008 \times d_1$	190	$0,006 \times d_1$	<input type="checkbox"/>	<input checked="" type="checkbox"/>	<input type="checkbox"/>
	4.2	140	$0,008 \times d_1$	170	$0,006 \times d_1$	<input type="checkbox"/>	<input checked="" type="checkbox"/>	<input type="checkbox"/>
N	1.1							
	1.2							
	1.3							
	1.4							
	1.5							
	1.6							
	2.1	240	$0,014 \times d_1$	280	$0,010 \times d_1$			<input type="checkbox"/>
	2.2	240	$0,014 \times d_1$	280	$0,010 \times d_1$			<input type="checkbox"/>
	2.3	240	$0,014 \times d_1$	280	$0,010 \times d_1$	<input type="checkbox"/>	<input type="checkbox"/>	<input type="checkbox"/>
	2.4	200	$0,011 \times d_1$	250	$0,008 \times d_1$			<input type="checkbox"/>
	2.5	200	$0,011 \times d_1$	250	$0,008 \times d_1$			<input type="checkbox"/>
	2.6	200	$0,011 \times d_1$	250	$0,008 \times d_1$	<input type="checkbox"/>	<input type="checkbox"/>	<input type="checkbox"/>
	2.7	140	$0,008 \times d_1$	170	$0,006 \times d_1$			<input type="checkbox"/>
	2.8	140	$0,008 \times d_1$	170	$0,006 \times d_1$			<input type="checkbox"/>
	3.1							
	3.2							
4.1								
4.2								
4.3								
4.4								
5.1								
5.2	110	$0,008 \times d_1$	150	$0,006 \times d_1$			<input type="checkbox"/>	
5.3								
S	1.1	110	$0,010 \times d_1$	150	$0,007 \times d_1$			<input type="checkbox"/>
	1.2	90	$0,008 \times d_1$	120	$0,006 \times d_1$			<input type="checkbox"/>
	1.3	50	$0,007 \times d_1$	70	$0,005 \times d_1$			<input type="checkbox"/>
	2.1	80	$0,008 \times d_1$	110	$0,006 \times d_1$			<input type="checkbox"/>
	2.2	30	$0,006 \times d_1$	50	$0,004 \times d_1$			<input type="checkbox"/>
	2.3	30	$0,006 \times d_1$	40	$0,004 \times d_1$			<input type="checkbox"/>
	2.4	30	$0,006 \times d_1$	40	$0,004 \times d_1$			<input type="checkbox"/>
	2.5	20	$0,006 \times d_1$	30	$0,004 \times d_1$			<input type="checkbox"/>
2.6	30	$0,006 \times d_1$	40	$0,004 \times d_1$			<input type="checkbox"/>	
H	1.1	120	$0,006 \times d_1$	150	$0,006 \times d_1$	<input type="checkbox"/>	<input checked="" type="checkbox"/>	
	1.2	100	$0,005 \times d_1$	130	$0,005 \times d_1$	<input type="checkbox"/>	<input checked="" type="checkbox"/>	
	1.3							
	1.4							
	1.5							

v_c = Schnittgeschwindigkeit · Cutting speed
 f_z = Vorschub pro Zahn · Feed per tooth

■ = sehr gut geeignet · very suitable
□ = gut geeignet · suitable

- Multifunktionales Hochleistungswerkzeug
- Hochgenauer Eckenradius
- 3 Baulängen verfügbar

- Multi-functional, high performance tool
- High-precision corner radius
- 3 lengths available

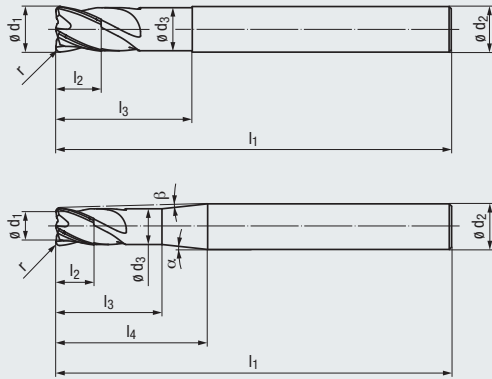

N

HM

DIN 6535
HA
HB

30°

Torus

1-2°

MMS
MQL

≤ 55
HRC

V_c/f_z
35



new

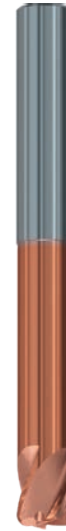

Allround

Beschichtung · Coating

TIALN

Einsatzgebiete – Material (siehe Seite 4)

Applications – material (see page 4)

- In schwer zerspanbaren Materialien einsetzbar
- Zum Schruppen, Schlichten sowie zum HSC-Schlichten geeignet

- For difficult to cut materials
- Suitable for roughing, finishing and HSC finishing

P 1.1-5.1

M 1.1-4.1

K 1.1-4.2

N 2.2-2.8, 5.2 2.1

S 1.1-2.6

H 1.1-1.2

$l_3 = 5 \times d_1$ – Lange Ausführung · Long design

Bestell-Code · Order code

3836A

$\varnothing d_1$ -0,02	r ±0,005	l_2	l_3	l_1	$\varnothing d_3$	l_4	$\varnothing d_2$ h5	α	β	Z (Flutes)	Dimens.- Code		
2	0,1	3	10	63	1,8	21,9	6	10°	5,5°	4	.002001	●	
2	0,2	3	10	63	1,8	21,9	6	10°	5,5°	4	.002002	●	
2	0,5	3	10	63	1,8	21,9	6	10°	5,5°	4	.002005	●	
3	0,2	3,5	15	63	2,8	24	6	10°	4°	4	.003002	●	
3	0,5	3,5	15	63	2,8	24	6	10°	4°	4	.003005	●	
4	0,3	4	20	63	3,8	26,2	6	10°	2,5°	4	.004003	●	
4	0,5	4	20	63	3,8	26,2	6	10°	2,5°	4	.004005	●	
4	1	4	20	63	3,8	26,2	6	10°	2,5°	4	.004010	●	
5	0,3	5	25	66	4,7	28,6	6	10°	1,5°	4	.005003	●	
5	0,5	5	25	66	4,7	28,6	6	10°	1,5°	4	.005005	●	
5	1	5	25	66	4,7	28,6	6	10°	1,5°	4	.005010	●	
6	0,3	6	30	68	5,6	—	6	—	—	4	.006003	●	
6	0,5	6	30	68	5,6	—	6	—	—	4	.006005	●	
6	1	6	30	68	5,6	—	6	—	—	4	.006010	●	
6	1,5	6	30	68	5,6	—	6	—	—	4	.006015	●	
6	2	6	30	68	5,6	—	6	—	—	4	.006020	●	
8	0,3	7	40	78	7,6	—	8	—	—	4	.008003	●	
8	0,5	7	40	78	7,6	—	8	—	—	4	.008005	●	
8	1	7	40	78	7,6	—	8	—	—	4	.008010	●	
8	2	7	40	78	7,6	—	8	—	—	4	.008020	●	
10	0,5	8	50	92	9,6	—	10	—	—	4	.010005	●	
10	1	8	50	92	9,6	—	10	—	—	4	.010010	●	
10	1,5	8	50	92	9,6	—	10	—	—	4	.010015	●	
10	2	8	50	92	9,6	—	10	—	—	4	.010020	●	
10	2,5	8	50	92	9,6	—	10	—	—	4	.010025	●	
10	3	8	50	92	9,6	—	10	—	—	4	.010030	●	
12	0,5	10	60	106	11,5	—	12	—	—	4	.012005	●	
12	1	10	60	106	11,5	—	12	—	—	4	.012010	●	
12	1,5	10	60	106	11,5	—	12	—	—	4	.012015	●	
12	2	10	60	106	11,5	—	12	—	—	4	.012020	●	
12	3	10	60	106	11,5	—	12	—	—	4	.012030	●	
12	4	10	60	106	11,5	—	12	—	—	4	.012040	●	



Hartmetall-Torusfräser – lange Ausführung
Solid carbide torus end mills – long design

N

$l_3 = 5 \times d_1$

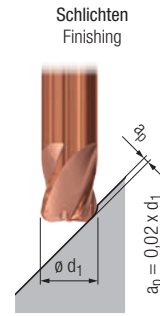
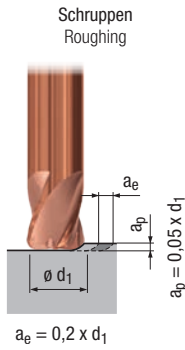

Gültig für · Valid for
3836A

	V_c [m/min]	f_z [mm]	V_c [m/min]	f_z [mm]				
P	1.1	250	$0,013 \times d_1$	300	$0,010 \times d_1$	<input type="checkbox"/>	<input checked="" type="checkbox"/>	<input type="checkbox"/>
	2.1	230	$0,012 \times d_1$	260	$0,009 \times d_1$	<input type="checkbox"/>	<input checked="" type="checkbox"/>	<input type="checkbox"/>
	3.1	200	$0,010 \times d_1$	230	$0,008 \times d_1$	<input type="checkbox"/>	<input checked="" type="checkbox"/>	<input type="checkbox"/>
	4.1	170	$0,009 \times d_1$	200	$0,007 \times d_1$	<input type="checkbox"/>	<input checked="" type="checkbox"/>	<input type="checkbox"/>
	5.1	150	$0,008 \times d_1$	180	$0,006 \times d_1$	<input type="checkbox"/>	<input checked="" type="checkbox"/>	<input type="checkbox"/>
M	1.1	140	$0,008 \times d_1$	180	$0,006 \times d_1$			<input type="checkbox"/>
	2.1	120	$0,008 \times d_1$	160	$0,006 \times d_1$			<input type="checkbox"/>
	3.1	100	$0,006 \times d_1$	120	$0,005 \times d_1$			<input type="checkbox"/>
	4.1	80	$0,006 \times d_1$	100	$0,005 \times d_1$			<input type="checkbox"/>
K	1.1	250	$0,014 \times d_1$	280	$0,010 \times d_1$	<input type="checkbox"/>	<input checked="" type="checkbox"/>	<input type="checkbox"/>
	1.2	250	$0,014 \times d_1$	280	$0,010 \times d_1$	<input type="checkbox"/>	<input checked="" type="checkbox"/>	<input type="checkbox"/>
	2.1	230	$0,011 \times d_1$	260	$0,008 \times d_1$	<input type="checkbox"/>	<input checked="" type="checkbox"/>	<input type="checkbox"/>
	2.2	230	$0,011 \times d_1$	260	$0,008 \times d_1$	<input type="checkbox"/>	<input checked="" type="checkbox"/>	<input type="checkbox"/>
	3.1	190	$0,011 \times d_1$	210	$0,008 \times d_1$	<input type="checkbox"/>	<input checked="" type="checkbox"/>	<input type="checkbox"/>
	3.2	190	$0,011 \times d_1$	210	$0,008 \times d_1$	<input type="checkbox"/>	<input checked="" type="checkbox"/>	<input type="checkbox"/>
	4.1	160	$0,008 \times d_1$	190	$0,006 \times d_1$	<input type="checkbox"/>	<input checked="" type="checkbox"/>	<input type="checkbox"/>
	4.2	140	$0,008 \times d_1$	170	$0,006 \times d_1$	<input type="checkbox"/>	<input checked="" type="checkbox"/>	<input type="checkbox"/>
N	1.1							
	1.2							
	1.3							
	1.4							
	1.5							
	1.6							
	2.1	240	$0,014 \times d_1$	280	$0,010 \times d_1$			<input type="checkbox"/>
	2.2	240	$0,014 \times d_1$	280	$0,010 \times d_1$			<input type="checkbox"/>
	2.3	240	$0,014 \times d_1$	280	$0,010 \times d_1$	<input type="checkbox"/>	<input type="checkbox"/>	<input type="checkbox"/>
	2.4	200	$0,011 \times d_1$	250	$0,008 \times d_1$			<input type="checkbox"/>
	2.5	200	$0,011 \times d_1$	250	$0,008 \times d_1$			<input type="checkbox"/>
	2.6	200	$0,011 \times d_1$	250	$0,008 \times d_1$	<input type="checkbox"/>	<input type="checkbox"/>	<input type="checkbox"/>
	2.7	140	$0,008 \times d_1$	170	$0,006 \times d_1$			<input type="checkbox"/>
	2.8	140	$0,008 \times d_1$	170	$0,006 \times d_1$			<input type="checkbox"/>
	3.1							
	3.2							
4.1								
4.2								
4.3								
4.4								
5.1								
5.2	110	$0,008 \times d_1$	150	$0,006 \times d_1$			<input type="checkbox"/>	
5.3								
S	1.1	110	$0,010 \times d_1$	150	$0,007 \times d_1$			<input type="checkbox"/>
	1.2	90	$0,008 \times d_1$	120	$0,006 \times d_1$			<input type="checkbox"/>
	1.3	50	$0,007 \times d_1$	70	$0,005 \times d_1$			<input type="checkbox"/>
	2.1	80	$0,008 \times d_1$	110	$0,006 \times d_1$			<input type="checkbox"/>
	2.2	30	$0,006 \times d_1$	50	$0,004 \times d_1$			<input type="checkbox"/>
	2.3	30	$0,006 \times d_1$	40	$0,004 \times d_1$			<input type="checkbox"/>
	2.4	30	$0,006 \times d_1$	40	$0,004 \times d_1$			<input type="checkbox"/>
2.5	20	$0,006 \times d_1$	30	$0,004 \times d_1$			<input type="checkbox"/>	
2.6	30	$0,006 \times d_1$	40	$0,004 \times d_1$			<input type="checkbox"/>	
H	1.1	120	$0,006 \times d_1$	150	$0,006 \times d_1$	<input type="checkbox"/>	<input checked="" type="checkbox"/>	
	1.2	100	$0,005 \times d_1$	130	$0,005 \times d_1$	<input type="checkbox"/>	<input checked="" type="checkbox"/>	
	1.3							
	1.4							
	1.5							

v_c = Schnittgeschwindigkeit · Cutting speed
 f_z = Vorschub pro Zahn · Feed per tooth

■ = sehr gut geeignet · very suitable
□ = gut geeignet · suitable

- Multifunktionales Hochleistungswerkzeug
- Hochgenauer Eckenradius
- 3 Baulängen verfügbar

- Multi-functional, high performance tool
- High-precision corner radius
- 3 lengths available

N

HM

DIN 6535
HA
HB

30°

Torus

1-2°

MMS
MQL

≤ 55 HRC

V_c/f_z
37



new



Allround

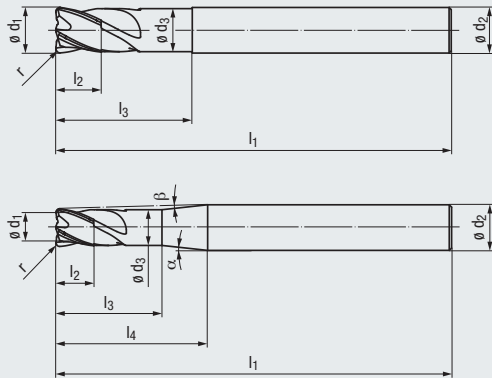

Beschichtung · Coating

TIALN

Einsatzgebiete – Material (siehe Seite 4)

Applications – material (see page 4)

- In schwer zerspanbaren Materialien einsetzbar
- Zum Schruppen, Schlichten sowie zum HSC-Schlichten geeignet

- For difficult to cut materials
- Suitable for roughing, finishing and HSC finishing

P 1.1-5.1

M 1.1-4.1

K 1.1-4.2

N 2.2-2.8, 5.2 2.1

S 1.1-2.6

H 1.1-1.2

l₃ = 8 x d₁ – Extra lange Ausführung · Extra long design

Bestell-Code · Order code

3837A

∅ d ₁	r	l ₂	l ₃	l ₁	∅ d ₃	l ₄	∅ d ₂ h5	α	β	Z (Flutes)	Dimens.- Code		
2	0,1	3	16	66	1,8	27,9	6	10°	4,5°	4	.002001	●	
2	0,2	3	16	66	1,8	27,9	6	10°	4,5°	4	.002002	●	
2	0,5	3	16	66	1,8	27,9	6	10°	4,5°	4	.002005	●	
3	0,2	3,5	24	72	2,8	33	6	10°	3°	4	.003002	●	
3	0,5	3,5	24	72	2,8	33	6	10°	3°	4	.003005	●	
4	0,3	4	32	76	3,8	38,2	6	10°	2°	4	.004003	●	
4	0,5	4	32	76	3,8	38,2	6	10°	2°	4	.004005	●	
4	1	4	32	76	3,8	38,2	6	10°	2°	4	.004010	●	
5	0,3	5	40	80	4,7	43,6	6	10°	1°	4	.005003	●	
5	0,5	5	40	80	4,7	43,6	6	10°	1°	4	.005005	●	
5	1	5	40	80	4,7	43,6	6	10°	1°	4	.005010	●	
6	0,3	6	48	86	5,6	–	6	–	–	4	.006003	●	
6	0,5	6	48	86	5,6	–	6	–	–	4	.006005	●	
6	1	6	48	86	5,6	–	6	–	–	4	.006010	●	
6	1,5	6	48	86	5,6	–	6	–	–	4	.006015	●	
6	2	6	48	86	5,6	–	6	–	–	4	.006020	●	
8	0,3	7	64	102	7,6	–	8	–	–	4	.008003	●	
8	0,5	7	64	102	7,6	–	8	–	–	4	.008005	●	
8	1	7	64	102	7,6	–	8	–	–	4	.008010	●	
8	2	7	64	102	7,6	–	8	–	–	4	.008020	●	



Hartmetall-Torusfräser – extra lange Ausführung
Solid carbide torus end mills – extra long design

N

$l_3 = 8 \times d_1$

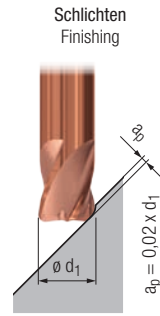
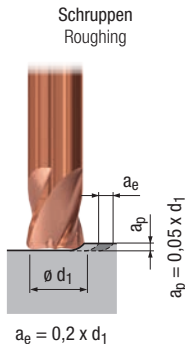

Gültig für · Valid for
3837A

	V_c [m/min]	f_z [mm]	V_c [m/min]	f_z [mm]			MMS MQL	
P								
1.1	250	$0,013 \times d_1$	300	$0,010 \times d_1$	<input type="checkbox"/>	<input checked="" type="checkbox"/>	<input type="checkbox"/>	<input checked="" type="checkbox"/>
2.1	230	$0,012 \times d_1$	260	$0,009 \times d_1$	<input type="checkbox"/>	<input checked="" type="checkbox"/>	<input type="checkbox"/>	<input checked="" type="checkbox"/>
3.1	200	$0,010 \times d_1$	230	$0,008 \times d_1$	<input type="checkbox"/>	<input checked="" type="checkbox"/>	<input type="checkbox"/>	<input type="checkbox"/>
4.1	170	$0,009 \times d_1$	200	$0,007 \times d_1$	<input type="checkbox"/>	<input checked="" type="checkbox"/>	<input type="checkbox"/>	<input type="checkbox"/>
5.1	150	$0,008 \times d_1$	180	$0,006 \times d_1$	<input type="checkbox"/>	<input checked="" type="checkbox"/>	<input type="checkbox"/>	<input type="checkbox"/>
M								
1.1	140	$0,008 \times d_1$	180	$0,006 \times d_1$			<input type="checkbox"/>	<input checked="" type="checkbox"/>
2.1	120	$0,008 \times d_1$	160	$0,006 \times d_1$			<input type="checkbox"/>	<input checked="" type="checkbox"/>
3.1	100	$0,006 \times d_1$	120	$0,005 \times d_1$			<input type="checkbox"/>	<input checked="" type="checkbox"/>
4.1	80	$0,006 \times d_1$	100	$0,005 \times d_1$			<input type="checkbox"/>	<input checked="" type="checkbox"/>
K								
1.1	250	$0,014 \times d_1$	280	$0,010 \times d_1$	<input type="checkbox"/>	<input checked="" type="checkbox"/>		<input type="checkbox"/>
1.2	250	$0,014 \times d_1$	280	$0,010 \times d_1$	<input type="checkbox"/>	<input checked="" type="checkbox"/>		<input type="checkbox"/>
2.1	230	$0,011 \times d_1$	260	$0,008 \times d_1$	<input type="checkbox"/>	<input checked="" type="checkbox"/>		<input type="checkbox"/>
2.2	230	$0,011 \times d_1$	260	$0,008 \times d_1$	<input type="checkbox"/>	<input checked="" type="checkbox"/>		<input type="checkbox"/>
3.1	190	$0,011 \times d_1$	210	$0,008 \times d_1$	<input type="checkbox"/>	<input checked="" type="checkbox"/>		<input type="checkbox"/>
3.2	190	$0,011 \times d_1$	210	$0,008 \times d_1$	<input type="checkbox"/>	<input checked="" type="checkbox"/>		<input type="checkbox"/>
4.1	160	$0,008 \times d_1$	190	$0,006 \times d_1$	<input type="checkbox"/>	<input checked="" type="checkbox"/>		<input type="checkbox"/>
4.2	140	$0,008 \times d_1$	170	$0,006 \times d_1$	<input type="checkbox"/>	<input checked="" type="checkbox"/>		<input type="checkbox"/>
N								
1.1								
1.2								
1.3								
1.4								
1.5								
1.6								
2.1	240	$0,014 \times d_1$	280	$0,010 \times d_1$			<input type="checkbox"/>	<input checked="" type="checkbox"/>
2.2	240	$0,014 \times d_1$	280	$0,010 \times d_1$			<input type="checkbox"/>	<input checked="" type="checkbox"/>
2.3	240	$0,014 \times d_1$	280	$0,010 \times d_1$	<input type="checkbox"/>	<input type="checkbox"/>	<input type="checkbox"/>	<input checked="" type="checkbox"/>
2.4	200	$0,011 \times d_1$	250	$0,008 \times d_1$			<input type="checkbox"/>	<input checked="" type="checkbox"/>
2.5	200	$0,011 \times d_1$	250	$0,008 \times d_1$			<input type="checkbox"/>	<input checked="" type="checkbox"/>
2.6	200	$0,011 \times d_1$	250	$0,008 \times d_1$	<input type="checkbox"/>	<input type="checkbox"/>	<input type="checkbox"/>	<input checked="" type="checkbox"/>
2.7	140	$0,008 \times d_1$	170	$0,006 \times d_1$			<input type="checkbox"/>	<input checked="" type="checkbox"/>
2.8	140	$0,008 \times d_1$	170	$0,006 \times d_1$			<input type="checkbox"/>	<input checked="" type="checkbox"/>
3.1								
3.2								
4.1								
4.2								
4.3								
4.4								
5.1								
5.2	110	$0,008 \times d_1$	150	$0,006 \times d_1$			<input type="checkbox"/>	<input checked="" type="checkbox"/>
5.3								
S								
1.1	110	$0,010 \times d_1$	150	$0,007 \times d_1$			<input type="checkbox"/>	<input checked="" type="checkbox"/>
1.2	90	$0,008 \times d_1$	120	$0,006 \times d_1$			<input type="checkbox"/>	<input checked="" type="checkbox"/>
1.3	50	$0,007 \times d_1$	70	$0,005 \times d_1$			<input type="checkbox"/>	<input checked="" type="checkbox"/>
2.1	80	$0,008 \times d_1$	110	$0,006 \times d_1$			<input type="checkbox"/>	<input checked="" type="checkbox"/>
2.2	30	$0,006 \times d_1$	50	$0,004 \times d_1$			<input type="checkbox"/>	<input checked="" type="checkbox"/>
2.3	30	$0,006 \times d_1$	40	$0,004 \times d_1$			<input type="checkbox"/>	<input checked="" type="checkbox"/>
2.4	30	$0,006 \times d_1$	40	$0,004 \times d_1$			<input type="checkbox"/>	<input checked="" type="checkbox"/>
2.5	20	$0,006 \times d_1$	30	$0,004 \times d_1$			<input type="checkbox"/>	<input checked="" type="checkbox"/>
2.6	30	$0,006 \times d_1$	40	$0,004 \times d_1$			<input type="checkbox"/>	<input checked="" type="checkbox"/>
H								
1.1	120	$0,006 \times d_1$	150	$0,006 \times d_1$	<input type="checkbox"/>	<input checked="" type="checkbox"/>		
1.2	100	$0,005 \times d_1$	130	$0,005 \times d_1$	<input type="checkbox"/>	<input checked="" type="checkbox"/>		
1.3								
1.4								
1.5								

v_c = Schnittgeschwindigkeit · Cutting speed
 f_z = Vorschub pro Zahn · Feed per tooth

■ = sehr gut geeignet · very suitable
□ = gut geeignet · suitable

	P	M	K	N	S	H
Werkzeugtyp Tool type	Hochleistungsfräser-Programm High performance end mill programme					
NR	Multi-Cut	Multi-Cut	Multi-Cut			
NF	Jet-Cut	TiNox-Cut	Jet-Cut		TiNox-Cut	
N	Jet-Cut	TiNox-Cut	Jet-Cut		TiNox-Cut	
W				Alu-Cut		
W				Fiber-Cut		
WR				Alu-Cut		
H						Hard-Cut
Werkzeugtyp Tool type	Hochleistungs-Universalfräser-Programm High performance universal end mill programme					
N	TOP-Cut	TOP-Cut	TOP-Cut	TOP-Cut	TOP-Cut	TOP-Cut

Druckerzeugnisse für Hochleistungswerkzeuge

Sales literature for high performance end mills

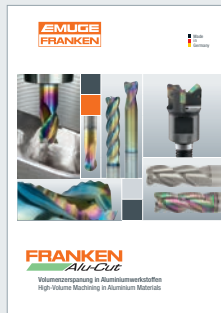

Druckerzeugnisse für Fräswerkzeuge mit besonderen Eigenschaften

Sales literature for milling tools with special characteristics

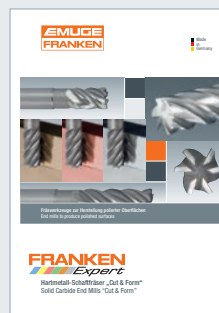

Hauptkatalog

Main catalogue

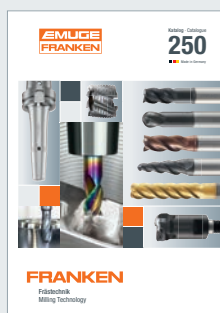



Mit den Kreissegment-Fräsern wurde eine Werkzeugfamilie geschaffen, welche einen höheren Bahnabstand bei der Vorschlicht- und Schlichtbearbeitung erlaubt. Diese Werkzeuge kommen vorwiegend im Formenbau sowie bei der Herstellung von Reifenformen, Turbinenschaukeln, Impellerblättern oder Blisks zum Einsatz.

Die technische Besonderheit dieser Fräser liegt bei den großen Radien im schneidenden Bereich der jeweiligen Ausführung, welche ganz neue Möglichkeiten in der Zerspanung bieten. Der große Radius simuliert einen Kugelfräser mit einem Schneidendurchmesser von 12 bis 3000 mm, auf Anfrage sogar größer.

Eine wichtige Rolle spielt hierbei das CAM-System, welches die Geometrie der Kreissegment-Fräser unterstützen und verrechnen muss. Somit können Bearbeitungszeiten drastisch reduziert und im Gegenzug die Oberflächenqualität der Bauteile erhöht werden.

The circle segment end mills constitute a new tool class which enable machining with a larger tool path distance during prefinishing and finishing operations. These tools are primarily used in mould-making as well as in the production of tyre moulds, turbine blades, impeller blades or blisks.

The technical specialty of these end mills are the large radii in the cutting area of the respective tool which offer entirely new possibilities in machining. The large radius simulates a ball-nose end mill with a cutting diameter of 12 to 3000 mm and even larger on request.

The CAM system which has to support and compute the geometry of the circle segment end mill, plays an important role here. As a consequence, machining times can be reduced significantly and at the same time the surface quality of the components is increased.

Übersicht der Kreissegment-Fräser

Overview of circle segment end mills

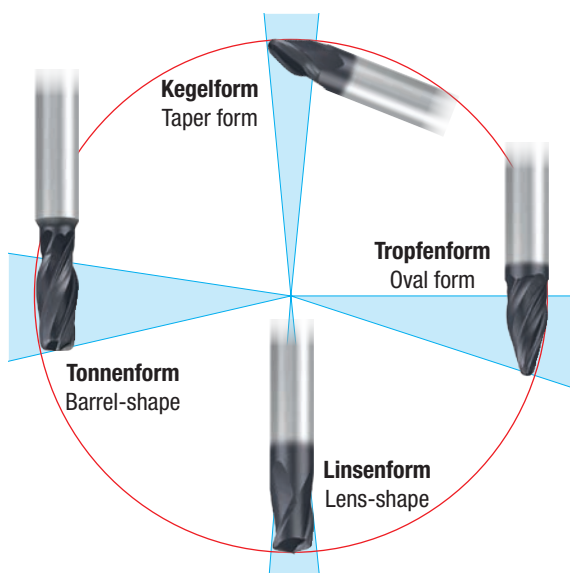

Vergleichsbeispiel: Kugelfräser – Kreissegment-Fräser mit Tropfenform

Comparison example: Ball nose end mill – circle segment end mill with oval form

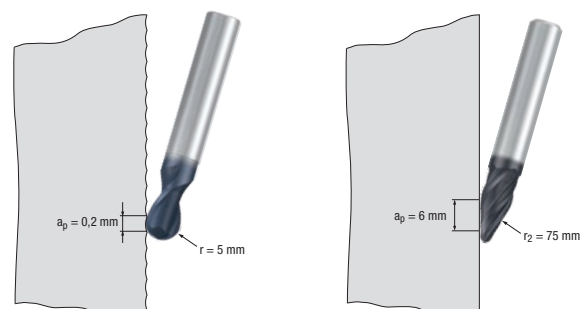

Ergebnis: Kreissegment-Fräser ermöglichen eine höhere axiale Zustellung (a_p) bei wesentlich besseren Oberflächengüten.

Result: Circle segment end mills enable a larger axial depth of cut (a_p) and a considerably better surface finish.



Wirtschaftlichkeitsberechnung für Kreissegment-Fräser
Economical calculation for circle segment end mills
www.frankenexpert.com

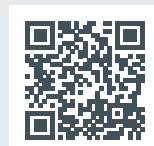

Durch die Verwendung von gekühlter Luft wird die Temperatur im Schneidenbereich herabgesetzt, wodurch höhere Schnittgeschwindigkeiten und Standzeiten erreicht werden können. Moderne Beschichtungen können durch diese Art der Kühlung erst alle Vorteile ausspielen, da eine Schädigung der Schneide durch Thermoschock vermieden wird.

Darüber hinaus werden die beim Kopierfräsen anfallenden sehr leichten Späne auch aus tiefen Aussparungen oder Kavitäten mit Hilfe der Kaltluftdüse entfernt.

Die Wirkungsweise der Kaltluftdüse basiert auf dem Prinzip des Wirbelrohrs, in dem zwei gegenläufige, rotierende Luftströme (ohne bewegte Teile) erzeugt werden. An einem Ende tritt die innere Strömung als nutzbare Kaltluft mit bis zu -40 °C aus. Der Anschluss erfolgt über einen Druckluftanschluss.

Cooled air reduces temperatures in the cutting area, which in turn permits higher cutting speeds and longer tool life. This type of cooling enables modern coatings to achieve their full potential, as damage to the cutting edge resulting from thermal shock is avoided.

Moreover, the cold-air nozzle helps to remove the tiny chips produced in copy milling even from deep recesses or cavities.

The function of the cold-air nozzle is based on the principle of the vortex tube, in which two opposed, rotating air streams are generated (without any moving parts). The internal air stream exits from one end, in the form of useable cold air with a temperature as low as -40 °C. All that is required is a normal pressurised air connection.

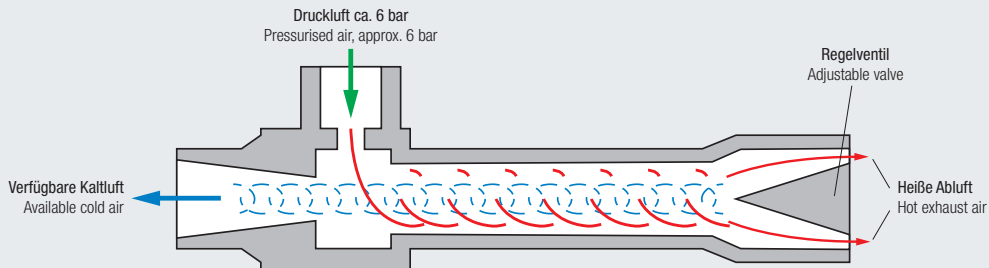

Temperatur gemessen am effektiven Austritt des Wirbelrohrs (nicht Düsenende)
Temperature, measured at the effective exit of the vortex tube (not the end of the nozzle)

Zuluft-Druck Supply air pressure [bar]	Temperatur der Nutzluft in °C bei einem Kaltluftanteil von Temperature of usable air in °C, with a cold air percentage of		
	25%	50%	75%
3	-31	-22	- 6
4	-35	-35	- 8
5	-39	-28	-10
6	-42	-31	-11
7	-46	-34	-13

Luftverbrauch bei Eingangstemperatur von 21 °C
Air consumption, with supply air temperature of 21 °C

Eingangsdruck Input pressure [bar]	Luftverbrauch Air consumption	Kapazität Capacity
6,9	7,08 l/s \cong 25,5 m ³ /h	226 kcal/h \cong 263 W

**Anwendungsbeispiel:
Standzeiterhöhung durch den Einsatz der Kaltluftdüse**

Werkstück: Formeinsatz gehärtet, Material K360 mit 63 HRC
Bearbeitung: Schichten des Formeinsatzes
Werkzeug: FRANKEN Hard-Cut
Schneidendurchmesser 10 mm, 2 Schneiden

Schnittwerte: $v_c = 240 \text{ m/min} \cdot n = 7639 \text{ min}^{-1}$
 $f_z = 0,12 \text{ mm} \cdot v_f = 1833 \text{ mm/min}$
 $a_p = 0,2 \text{ mm} \cdot a_e = 0,2 \text{ mm}$

Standzeit ohne Kühlung	Standzeit mit Kaltluftdüse
98 Minuten	130 Minuten

Durch den Einsatz der Kaltluftdüse konnte die Standzeit um 33% erhöht werden.

**Application example:
Increased tool life using the cold-air nozzle**

Workpiece: Hardened mould, material K360 with 63 HRC
Operation: Finishing the mould
Tool: FRANKEN Hard-Cut
Cutting diameter 10 mm, 2 flutes

Cutting conditions: $v_c = 240 \text{ m/min} \cdot n = 7639 \text{ rpm}$
 $f_z = 0.12 \text{ mm} \cdot v_f = 1833 \text{ mm/min}$
 $a_p = 0.2 \text{ mm} \cdot a_e = 0.2 \text{ mm}$

Tool life without coolant	Tool life with cold-air nozzle
98 minutes	130 minutes

By using the cold-air nozzle, it was possible to increase the tool life by 33%.



Kaltluftdüse
Cold-Air Nozzle



Lieferumfang:

- Mit biegsamem Schlauch (Länge ca. 300 mm) für kalte Nutzluft
- Schalldämpfer (SN14) für heiße Abluft
- Kugelhahn mit Anschlussstück (ST 1/4) für Zuluftschlauch (NW6) mit Schnellwechselkupplung (NW7.2)

Delivery includes:

- With flexible hose (length approx. 300 mm) for cold air
- Silencer (SN14) for hot exhaust air
- Ball-valve with fitting (1/4") for inlet hose (6 mm) with quick-change attachment (7.2 mm)

Bestell-Code · Order code		6910
Länge (ohne Schlauch) Length (without hose)	Dimens.- Code	
225 mm	.15	●

Ersatzschlauch
Spare Hose



Bestell-Code · Order code		6910
Länge Length	Dimens.- Code	
≈ 300 mm	.20	●
≈ 400 mm	.22	●
≈ 500 mm	.21	●

Halterungen für die Kaltluftdüse
Holders for the Cold-Air Nozzle



Klemmarm mit Grundhalter
Socket with basic holder



Klemmarm mit Magnethalter
Socket with magnetic shoe



Klemmarm
Socket



Grundhalter für Klemmarm
Basic holder for socket



Magnethalter für Klemmarm
Magnetic shoe for socket



Bestell-Code · Order code		6910				
Abmaße Dimensions	Dimens.- Code					
ø 45 x 68 mm	.24	●				
ø 80 x 80 mm	.25		●			
ø 80 x 17 mm	.26					●
ø 32 x 63 mm	.27			●		
ø 45 x 20 mm	.32				●	

Kaltluftdüsen-Anbauset

Cold-Air Nozzle Attachment Set



Bestell-Code · Order code	6910
Dimens.-Code	
.12	•

Lieferumfang:

- 1 x Klemmarm mit Grundhalter (Art.-Nr.: 6910.24)
- 1 x Anschlussschlauch 300 mm
- 1 x Winkel-Verschraubung G 1/4
- 1 x Verschraubung G 1/4
- 2 x Blindstopfen G 1/4

Delivery includes:

- 1 x Socket with basic holder (art. No. 6910.24)
- 1 x Connecting hose 300 mm
- 1 x Elbow coupling G 1/4
- 1 x Screw G 1/4
- 2 x Sealing plugs G 1/4

Kaltluftdüsen-Montageset 1

Cold-Air Nozzle Assembly Set 1

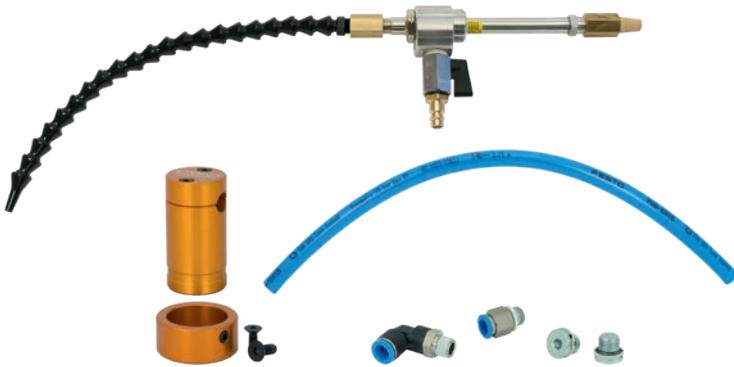

Bestehend aus 1 Kaltluftdüse (Art.-Nr.: 6910.15) und 1 Kaltluftdüsen-Anbauset (Art.-Nr.: 6910.12)
Consists of 1 cold-air nozzle (art. no. 6910.15) and 1 cold-air nozzle attachment set (art. no. 6910.12)

Bestell-Code · Order code	6910
Dimens.-Code	
.11	•

Kaltluftdüsen-Montageset 2

Cold-Air Nozzle Assembly Set 2

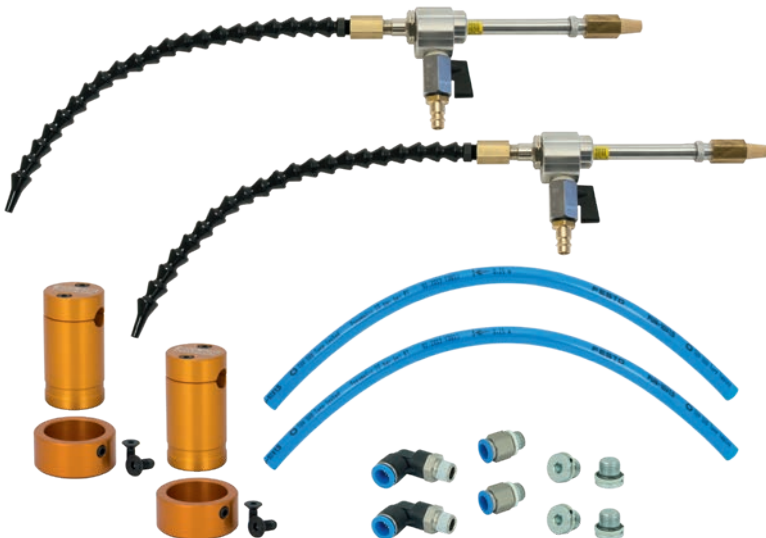

Bestehend aus 2 Kaltluftdüsen (Art.-Nr.: 6910.15) und 2 Kaltluftdüsen-Anbausets (Art.-Nr.: 6910.12)
Consists of 2 cold-air nozzles (art. no. 6910.15) and 2 cold-air nozzle attachment sets (art. no. 6910.12)

Bestell-Code · Order code	6910
Dimens.-Code	
.10	•

In unseren Unternehmen ist die Abteilung „Anwendungstechnik“ die Service- und Dienstleistungsabteilung für den weltweit bestehenden Kundenkreis. Für die von EMUGE-FRANKEN angebotenen Produkte stellt dieses Expertenteam folgende Leistungen zur Verfügung:

- Weltweite telefonische Beratung und Unterstützung bei der Lösung technischer Probleme
- Mitarbeit bei der Erarbeitung von Konzepten und Vorschlägen zur Optimierung des Fertigungsablaufes beim Kunden
- Durchführung von Versuchen mit spezifischen Kundenmaterialien in einer eigens dafür eingerichteten Versuchsabteilung zur optimalen Werkzeugauswahl und -empfehlung
- Entwicklung und Konstruktion kundenspezifischer Sonderwerkzeuge
- Einsatz von Servicetechnikern
- Durchführung von produktbezogenen Schulungen und Seminaren weltweit

At EMUGE-FRANKEN, the Technical Service Department is the service and consulting partner for our customers worldwide. Our team of service technicians will be happy to help you in any of the following ways:

- Worldwide telephone consulting and support in the solution of technical problems
- Active support in the development of work strategies and in the optimisation of production processes
- Cutting trials with specific customer materials in a special workshop fitted exclusively for that purpose, for the perfect tool selection
- Development and construction of special tools made to customer's specifications
- Visits to customers' workshops and active support on location
- Product-related training courses and seminars arranged at any place worldwide

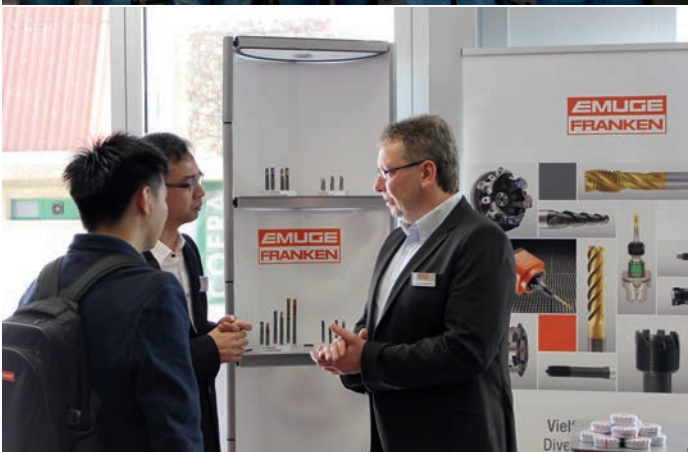
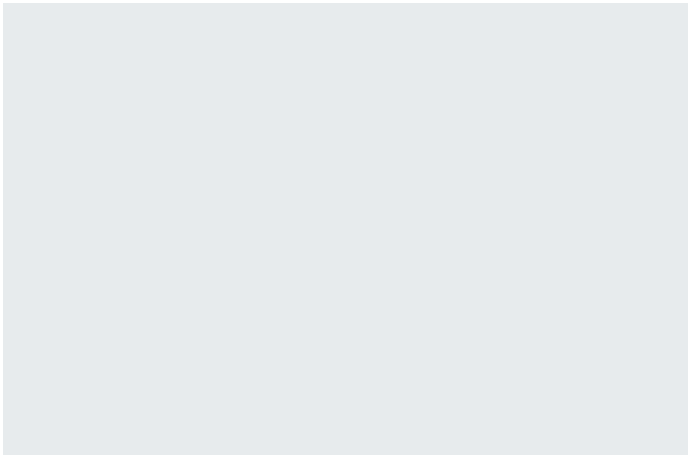

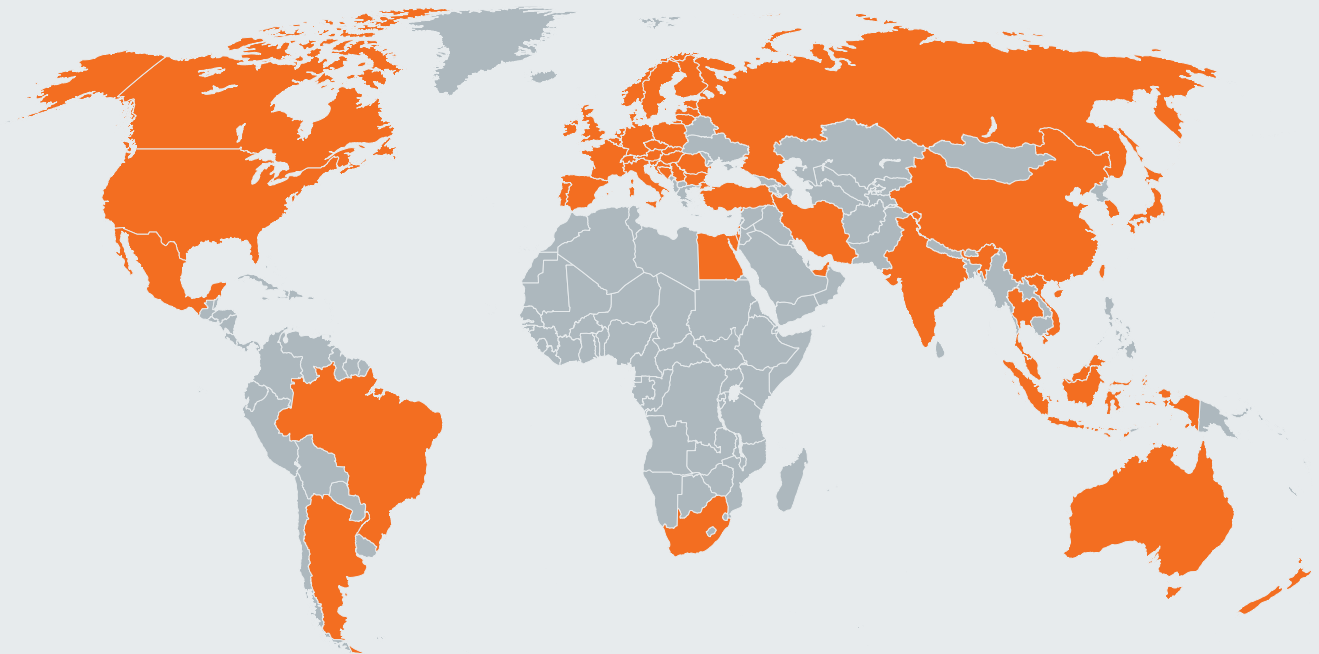

EMUGE-FRANKEN Vertriebspartner finden Sie auf www.emuge-franken.com/vertrieb
EMUGE-FRANKEN sales partners, please see www.emuge-franken.com/sales

EMUGE-Werk Richard Glimpel GmbH & Co. KG
Fabrik für Präzisionswerkzeuge

🏠 Nürnberger Straße 96-100
91207 Lauf
GERMANY

☎ +49 9123 186-0
📠 +49 9123 14313

FRANKEN GmbH & Co. KG
Fabrik für Präzisionswerkzeuge

🏠 Frankenstraße 7/9a
90607 Rückersdorf
GERMANY

☎ +49 911 9575-5
📠 +49 911 9575-327